



PRODUCTS 2020

CONTENTS

ALC-3316 Loudspeaker Controller	3
PMA Loudspeaker Controllers (9 Models)	4
SCR-2215sm Loudspeaker	6
SCR-2115sm Loudspeaker	7
SCR-15sm Loudspeaker	8
SR-212ai Loudspeaker	9
SR-12ai Loudspeaker	10
S-12sm Loudspeaker	11
SCRS-8ai Loudspeaker	15
SR-26im Loudspeaker	16
SR-6im/SR-6im-P Loudspeaker	18
SCRS-6iw / 6iw-P Loudspeaker	20
SCRS-6c-iw Loudspeaker	21
SCRS-6c-ica Loudspeaker	22
SR-25im / SR-25im-P Loudspeaker	23
SCRS-25ica Loudspeaker	25
SCRS-5iw Loudspeaker	26
LFC-10sm Subwoofer	27
LFC-210im Subwoofer	28
LFC-12v Subwoofer	29
LFC-212ai Subwoofer	30
LFC-14sm Subwoofer	31
LFC-15sm Subwoofer	32
LFC-18sm Subwoofer	33
LFC-21sm Subwoofer	34
LFC-24sm Subwoofer	35
PIVOT BRACKET KIT	36
SYSTEM CONTROLLER	37

ALC-3316 Loudspeaker Controller

KEY FEATURES

- **8-Fully-Balanced** Analog Audio Inputs (all channels)
- **9 Amplifier Channels** in 1U Chassis: 3 x 300W + 6 x 100W (bridgeable)
- **Configurable** to 4 x 300W + 4 x 100W; 5 x 300W + 2 x 100W; 6 x 300W
- **Installer Programmable 96kHz/32-bit DSP:**
 - 160 Parametric EQ Filters (20 per channel)
 - Compensation Filters for Perforated Screen, Room Boundary Effects, etc.
 - Level and 70msec Delay per channel
 - 8 x 8 Matrix Bass Management (Bass Steering)
 - Loudspeaker Processing for all PRO and THEORY Models
 - Input Trim
 - Matrix Signal Routing
 - Clip Limiter
 - Internal Full and Band-Limited Pink Noise, Sine Signals
- **Universal AC and 12V / Contact Closure Trigger**



DESCRIPTION

The ALC-3316 Amplified Loudspeaker Controller embodies the latest PRO Power and Advanced DSP technology in a compact 1U chassis. Developed to provide a low-cost option for smaller cinema systems or residential/commercial distributed audio applications, the ALC-3316 is configurable to provide up to **one-thousand-eight-hundred watts** of total power, yet weighs just **12 pounds**.

In its stock configuration, the 3316 provides **9** channels of power amplification and on-board DSP: 3 x 300W + 6 x 100W — an ideal combination for 7.2 or 5.2.2 Atmos surround systems where the 300W channels can power dual subwoofers and the 100W channels can power the front and surround channels, including bi-amplification of the critical center-channel speaker. For added flexibility, each of the 100W channel-pairs can be bridged together to create a single 300W channel. Iterations up to 6 x 300W can be dealer-configured using CONFIGURATOR™ Amplifier Configuration and System Optimization software.

Like the PRO PMA series of amplifier/processors, the ALC-3316 includes fully balanced analog audio inputs and offers advanced installer-programmable DSP features which make even the most advanced audio systems easy to deploy and optimize. Speaker programming, matrix bass-management, room acoustic compensation filters, high and low pass filters, parametric EQ, gain and delay adjustments are available via PRO's easy-to-use, CONFIGURATOR™ software package.

SPECS

APPLICATION:	Amplification of PRO loudspeakers & subwoofers in surround sound & distributed audio applications
POWER OUTPUT: (per channel, configurable)	3 x 300W + 6 x 100W 4 x 300W + 4 x 100W 5 x 300W + 2 x 100W 6 x 300W
1/8 POWER (all ch bridged):	281W (959 Btu/Hr.)
IDLE POWER:	36W (123 Btu/Hr.)
STANDBY POWER:	11W (37.5 Btu/Hr.)
CONTROLS:	Power, 12VDC trigger/standby, software signal routing, filters, loudspeaker programming
FRONT DISPLAY:	Channel number, signal routing, installed loudspeaker program
REAR LED INDICATORS:	Power, DSP activity, bridged status, standby/protect modes
DIMENSIONS:	1.75"H (1RU) x 19.0"W x 15.6"D
WEIGHT:	12 lbs.

PMA Loudspeaker Controller (9 Models)

KEY FEATURES

- **Installer Programmable DSP Processing for All PRO Loudspeakers**
 - **Software Selectable Input Routing for All Channels Plus Looping Outputs**
 - **Installer Selectable Acoustic Compensation Filters**
 - Perforated Screen Compensation
 - Room Boundary Loading Compensation
 - 80Hz High-Pass Filter
 - Level Control
 - Parametric EQ Filters
 - **Ultra Low Noise Audio Converters: 123dB Dynamic Range**
 - **Configurable Amplifier Channel Powers: 200W, 450W and 1000W**
 - **Balanced Audio Inputs with Transformer Isolation***
 - **Up to 4 Channels and 4000W** in 2U Chassis**
 - 5.1 Bi-Amp System with Dual Subs in 6U Total Rack Space
 - 7.1 Bi-Amp System with Dual Subs in 8U Total Rack Space
- * Transformers optional ** 230V Operation recommended*



DESCRIPTION

Combining high efficiency amplification with advanced DSP processing, the PMA (Programmable Modular Amplifier) series of products introduces operational and performance refinements in a highly adaptable design. Each PMA loudspeaker controller employs a common “digital mainframe” to which power modules of 200, 450, or 1000 watts can be mounted. Flexible by design, each mainframe is populated with either two or four channels of amplification based on the system’s needs and specific loudspeaker or subwoofer application. By allowing the mix of modules, the PMA loudspeaker controller provides efficient use of power, supplying the appropriate wattage level needed for each specific application (i.e. 1000 watt modules may be used to drive subwoofers, while 450 watt modules may be mixed with 200 watt units to bi-amplify the low-frequency and higher efficiency high-frequency drivers respectively).

As with all PRO products, high resolution digital signal processing (DSP) lays at the heart of the PMA design. High resolution filtering allows PRO engineers to attain levels of technical accuracy orders of magnitude beyond previous designs. When driven by the PMA, the output of each loudspeaker precisely mimics the input signal of its assigned channel, rendering performance tolerances previously only attainable at the pre-amp and power-amp level. The resulting resolution of detail and musical accuracy set a new standard for lifelike portrayal of music and video soundtracks alike.

In addition to its modular design, the PMA provides an installer pro-

grammable platform from which any channel of the loudspeaker controller can be assigned a proprietary DSP filter matching any driver in a multi-way PRO loudspeaker system. A mini-USB interface and customized Microsoft Windows utility make programming of a complete system quick and easy. For greater flexibility, looping outputs allow multiple PMA chassis to be connected and share pre or post DSP processed signals. This is especially useful for installations employing multiple side channel loudspeakers, or where sophisticated multi-subwoofer configurations are used to address room modes.

Built on proven Class-D technology from ICEPower, each PMA loudspeaker controller operates efficiently, providing generous power while producing little heat. A balanced design, all connections are made via transformer isolated (optional) XLR inputs, minimizing ground-loop hum and buzz problems. In addition, each amp employs world class A-D and D-A converters with native dynamic range of 123dB!

SPECS

See next page for PMA specs

PMA Amplifier-Processor Specifications

Specification	2222	4400	4242	4444	9900	9922	9942	9944	9999
Power Ch 1, 4 ohms	200W	450W	450W	450W	1000W	1000W	1000W	1000W	1000W
Power Ch 2, 4 ohms	200W	450W	200W	450W	1000W	1000W	1000W	1000W	1000W
Power Ch 3, 4 ohms	200W	-	450W	450W	-	200W	450W	450W	1000W
Power Ch 4, 4 ohms	200W	-	200W	450W	-	200W	200W	450W	1000W
Voltage Gain	27dB								
Power Requirements, 1/8 Power, pink noise, 120VAC, all channels driven	92W 314 Btu/hr	96W 328 Btu/hr	136W 464 Btu/hr	180W 614 Btu/hr	173W 590 Btu/hr	215W 734 Btu/hr	237W 809 Btu/hr	259W 884 Btu/hr	338W 1153 Btu/hr
Idle Power	32W 109 Btu/hr	28W 96 Btu/hr	38W 130 Btu/hr	44W 150 Btu/hr	34W 116 Btu/hr	46W 157 Btu/hr	49W 167 Btu/hr	52W 177 Btu/hr	60W 205 Btu/hr
Standby Power	20W 68 Btu/hr	14W 48 Btu/hr	26W 89Btu/hr	32W 109 Btu/hr	15W 51 Btu/hr	21W 72 Btu/hr	24W 82 Btu/hr	27W 92 Btu/hr	22W 75 Btu/hr
Input Impedance	24k Ohms								
Input Sensitivity									
200W channels	1.3V								
450W channels	1.9V								
1000W channels	2.8V								
Damping Factor									
200W channels	>200, 4-ohm load; >400, 8-ohm load								
450W channels	>200, 4-ohm load; >400, 8-ohm load								
1000W channels	>800, 4-ohm load; >1600, 8-ohm load								
Frequency Response*	20Hz-20kHz +/- 0.2dB* *1000W Ch 2 and 3 20Hz-3kHz +0,-3dB								
Idle Noise, flat program, A-weighting									
200W channels	-78dBV (0.00013V)								
450W channels	-77dBV (0.00014V)								
1000W channels	-73dBV (0.00022V)								
Idle Noise, speaker program (typ.), A-weighting									
200W channels	-81dBV (0.00009V)								
500W channels	-80 dBV (.00010V)								
1000W channels	-76 dBV (0.00016V)								
Signal to Noise									
200W channels	108dB								
450W channels	109.5dB								
1000W channels	108dB								
Distortion, 1kHz, 1dB below max power output	<0.07%								
Dimensions	19.0" W x 3.5" H x 16.7" D								
Net Weight	13lbs.	14lbs.	14lbs.	15lbs.	15lbs.	16lbs.	17lbs.	17lbs.	20lbs.
Shipping Weight	18lbs.	19lbs.	19lbs.	20lbs.	20lbs.	21lbs.	22lbs.	22lbs.	25lbs.

*SPECIFICATIONS SUBJECT TO CHANGE WITHOUT NOTICE

SCR-2215sm Loudspeaker

KEY FEATURES

- Three-Way Reference Loudspeaker System
- Dual Professional 15-inch 1400W Woofers with 4-inch Voice Coils
- 1.4-inch Coaxial Compression Driver on 90° x 60° Constant Directivity Horn
- High Sensitivity: 102dB LF; 114dB MF/HF
- Configurable Modular Enclosure; Only 16 inches Deep
- Maximum Output: >130dB
- Designed for Placement Behind Acoustically Transparent Screen
- 8th Order Crossover Slopes
- DSP Performance Optimized
- Requires Four Channels of PRO Loudspeaker Controller Amplification
- Capable of "Reference Level" at >12 Meters



DESCRIPTION

Designed to excel in even the most demanding installations, the SCR-2215sm is a powerful dual woofer, three-way speaker providing incredible dynamics and high SPL levels with unrivaled visceral impact.

Employing a sophisticated coaxial compression driver mounted to an 18" x 22" large format horn, each driver is optimized across a narrower frequency range. Power handling and dynamic range are increased while providing extended bandwidth, resulting in a smooth, effortless presentation of vocals and instrumentation, and a true-to-life presentation of scale. Low frequency duties are performed by dual 15" woofers with over 350 sq. inches of combined surface area. Each driver is supported by dual ports and powered by a massive motor system, resulting in a system sensitivity of 102dB. Massive 4" voice coils maximize thermal power handling, allowing the SCR-2215sm to reproduce live concert sound pressure levels for extended periods without fear of driver failure.

Proprietary Digital Signal Processing (DSP) is employed for all crossover functions, time correction, and high resolution frequency response shaping. With signal filtration achieved prior to amplification and no passive filter networks in the signal path, the output stage of each amp channel is directly wired to its associated driver, maximizing power transfer and control. The result is tight, accurate bass delivered with the visceral impact experienced in the commercial theater or concert setting.

The SCR-2215sm and companion PRO loudspeaker controllers are part of a sophisticated digital cinema system. Maximum output is >130dB, making the SCR-2215 suitable for large to very large room applications.

SPECS

APPLICATION:	Quad-amplified large format screen channel
LF SECTION:	Two 15" professional grade woofers with 4" voice coils
MF / HF SECTION:	State-of-the-art, wide-bandwidth (>20kHz) coaxial compression driver 90° x 60° horn
CROSSOVER:	8th order acoustic via DSP
POWER HANDLING:	2800W LF / 150W MF / 80 HF
SENSITIVITY:	102dB LF / 114dB MF / 114db HF
POWER REQUIREMENTS:	Requires four channels of PRO amplification
POWER RECOMMENDATION:	1000W x2 LF / 450W MF / 200W HF
FREQUENCY RANGE:	32Hz – 24kHz
MAXIMUM OUTPUT:	>130dB
NOMINAL IMPEDANCE:	4-ohms LF / 8-ohms MF / 8-ohms HF
DIMENSIONS:	66"H x 22"W x 16"D
WEIGHT:	36lbs. (MF/HF module) 89lbs. (LF module each)

SCR-2115sm Loudspeaker

KEY FEATURES

- Three-Way Screen Channel Loudspeaker System
- Professional 15-inch 1400W Woofer with 4-inch Voice Coil
- 2-inch Coaxial Compression Driver on 90° x 60° Constant Directivity Horn
- High-Sensitivity: 95dB LF; 114dB MF/HF
- Configurable Modular Enclosure; Only 16 inches Deep
- Maximum Output: >130dB
- Designed for Placement behind Acoustically Transparent Screen
- 8th Order Crossover Slopes
- DSP Performance Optimized
- Requires Tri-Amplification via PRO Loudspeaker Controllers



DESCRIPTION

The SCR-2115sm offers the perfect balance of ultimate fidelity and unbri-dled power. A three-way loudspeaker, it employs the same sophisticated coaxial compression driver found in our larger models. Combining two subsystems in one, each driver is performance optimized across a nar-rower frequency range. Power handling and dynamic range are increased while providing extended bandwidth, resulting in an effortless presenta-tion of vocals and instrumentation with unrivaled detail, and the dynamics that give movie soundtracks and music a believable sense of scale.

Low frequency duties of the SCR-2115sm are performed by a profession-al-grade 15" woofer powered by a massive motor system. The 4" voice coil maximizes thermal power handling, allowing live concert sound pressure levels for extended periods without fear of driver failure.

Proprietary Digital Signal Processing (DSP) is employed for all crossover functions, time correction, and very high resolution frequency response shaping, eliminating restrictive passive filter networks from the signal path. With signal filtration achieved prior to amplification, the output stage of each amp channel is directly wired to the input terminals of its associated driver, maximizing power transfer and control. Bass is tight and accurate, and delivered with the visceral slam experienced in the commercial the-ater or concert setting.

The SCR-2115sm and companion PRO amplifiers are part of a sophisticat-ed digital cinema system employing proprietary DSP. Maximum output is >130 dB, making the SCR-2115sm the loudspeaker of choice when ultra high-resolution audio and true-to-life cinema are demanded from a single, dual-purpose system.

SPECS

APPLICATION:	Tri-amplified large format screen channel loudspeaker, audiophile stereo playback
LF SECTION:	15" professional grade woofer with 4" voice coil
MF / HF SECTION:	State-of-the-art wide-bandwidth (>20kHz) coaxial compression driver. 90° x 60° horn
CROSSOVER:	8th order acoustic via DSP
POWER HANDLING:	1400W LF / 150W MF / 80W HF
SENSITIVITY:	95dB LF / 114dB MF / 114dB HF
POWER REQUIREMENTS:	Requires tri-amplification via PRO loudspeaker controllers
POWER RECOMMENDATION:	1000W LF / 450W MF / 200W HF
FREQUENCY RANGE:	34Hz – 21kHz
MAXIMUM OUTPUT:	>130dB
NOMINAL IMPEDANCE:	4-ohms LF / 8-ohms MF / 8-ohms HF
DIMENSIONS:	42"H x 22"W x 16"D
WEIGHT:	36 lbs. (MF/HF module) 89 lbs. (LF module)

SCR-15sm Loudspeaker

KEY FEATURES

- Professional 15-inch, 1400W Woofer with 4-inch Voice Coil
- Professional 3-inch Compression Driver on 90° x 60° Constant Directivity Horn
- High-Sensitivity: 95dB LF; 111dB HF
- Maximum Output: >130dB
- Only 16-inches Deep
- Designed for Placement Behind Acoustically Transparent Screen
- 8th Order Crossover Slopes
- 4-ohm Nominal Impedance LF; 8-ohms HF
- DSP Performance Optimized
- Requires Bi-Amplification via PRO loudspeaker Controllers



DESCRIPTION

The SCR-15sm "Screen Channel" loudspeaker utilizes large format professional-grade components to reproduce the acoustic scale and weight of Cinematic soundtracks. At its foundation, a 15" woofer employs a massive motor system with 4" voice coil to maximize thermal power handling, allowing the SCR-15sm to produce sustained high SPL levels with ease and without harsh distortion. Like all PRO cinema loudspeakers, the crossover of the SCR-15sm is accomplished in DSP and therefore eliminates dynamic compression associated with traditional home audio loudspeakers that rely on passive crossover networks in the signal path. By direct coupling the drivers to the output stage of its companion PRO loudspeaker controller, power transfer is maximized, as is damping factor, resulting in bass that is tight and highly defined. High frequencies are supplied by a 3" aluminum diaphragm compression driver mated to an optimized constant directivity horn with more than 396 sq. inches total radiating area. Dynamics are effortless, as the system's movement of air produces a visceral presentation matched only by the live experience.

Designed as part of an integrated digital cinema system, the SCR-15sm and companion PRO loudspeaker controller employ proprietary Digital Signal Processing (DSP) for high-resolution crossover and time correction filters. Its drivers sum seamlessly to project life like images in three dimensional space; creating an immersive soundfield equaled only by state-of-the-art commercial theater systems. Maximum output is >130dB, making the SCR-15sm perfectly suited for mid-sized and large room applications.

SPECS

APPLICATION:	Bi-amplified large format screen channel loudspeaker
LF SECTION:	15" professional grade woofer with 4" voice coil
HF SECTION:	3" professional-grade compression driver / aluminum diaphragm with Mylar surround. 90° x 60° horn
CROSSOVER:	8th order acoustic via DSP
POWER HANDLING:	1400W LF / 220W HF
SENSITIVITY:	95dB LF / 111dB HF
POWER REQUIREMENTS:	Requires bi-amplification via PRO loudspeaker controllers
POWER RECOMMENDATION:	450W LF / 450W HF
FREQUENCY RANGE:	34Hz – 21kHz
MAXIMUM OUTPUT:	>130dB
NOMINAL IMPEDANCE:	4-ohms LF / 8-ohms HF
DIMENSIONS:	42"H x 22"W x 16"D
WEIGHT:	35 lbs. (HF module) 89 lbs. (LF module)

SR-212ai Loudspeaker

KEY FEATURES

- Architectural Installation™ Cabinet Design: 7.5-inch Total Depth for Easy Built-In Installation
- Suitable for Both Screen and Effects Channel Applications
- Dual Professional 12-inch, 1400W Woofers with 4-inch Voice Coils
- Professional 1-inch Compression Driver on Elliptical Constant Directivity Horn
- Ultra-Purity™ Advanced Polymer Compression Driver
- Maximum Output: >130dB
- 8th Order Crossover Slopes
- 4-ohm Nominal Impedance LF; 8-ohms HF
- DSP Performance Optimized
- Requires Tri-Amplification via PRO Loudspeaker Controllers
- **PRO PIVOT AIMING BRACKETS INCLUDED**



DESCRIPTION

The SR-212ai loudspeaker provides a dynamic, high output solution for screen or effects channels applications when maximum SPL and impact are required, but space is at a premium. A derivative of the SR-12ai design, the SR-212ai utilizes a second matching enclosure employing only the 12" woofer found in the main speaker. When mated to the SR-12ai, the two enclosures form a powerful dual 12" woofer loudspeaker system with low-frequency sensitivity of 96dB and an impressive total power handling spec of 2800 watts. The result is a smooth and detailed presentation of low frequency information with a significant increase in visceral slam, allowing the audience to experience the impact of a broad range of sound effects in a true-to-life manner, thus heightening believability. In addition, the SR-212ai can go loud when needed, achieving high SPL levels with no sense of strain, providing an effortless and non-fatiguing presentation of music and film soundtracks alike.

At only 7.5" in depth, the shallow enclosure design makes the SR-212ai easy to install with minimal build-out.

Developed as part of an integrated digital cinema system, the SR-212ai and companion PRO Loudspeaker Controller employ advanced Digital Signal Processing (DSP). As in commercial cinema systems, the SR-212ai is tri-amplified to maximize the performance of each driver in the system. With maximum output exceeding 130dB, it is ideal for use in medium, and large sized rooms where loudspeaker depth limitations may be a concern.

SPECS

APPLICATION:	Tri-amplified architectural format screen or surround channel loudspeaker
LF SECTION:	Dual 12" professional grade woofers with 4" voice coil
HF SECTION:	1" professional-grade compression driver / polymer diaphragm, 80° x 60° elliptical horn
CROSSOVER:	8th order acoustic via DSP
POWER HANDLING:	2800W LF / 120W HF
SENSITIVITY:	96dB LF / 108dB
POWER REQUIREMENTS:	Requires tri-amplification via PRO loudspeaker controller
POWER RECOMMENDATION:	450W x 2 LF / 200W HF
FREQUENCY RANGE:	38Hz - 24kHz
MAXIMUM OUTPUT:	>130dB
NOMINAL IMPEDANCE:	4-ohms LF / 8-ohms HF
DIMENSIONS:	72" H x 14" W x 7.5" D
WEIGHT:	51 lbs. (LF/HF module) 49 lbs. (LF module only)

SR-12ai Loudspeaker

KEY FEATURES

- Architectural Installation™ Cabinet Design: 7.5-inch Total Depth for Easy Built-In Installation
- Suitable for Both Screen and Effects Channel Applications
- Professional 12-inch, 1400W Woofer with 4-inch Voice Coil
- Professional 1-inch Compression Driver on Elliptical Constant Directivity Horn
- Ultra-Purity™ Advanced Polymer Compression Driver
- Maximum Output: >130dB
- 8th Order Crossover Slopes
- 4-ohm Nominal Impedance LF; 8-ohms HF
- DSP Performance Optimized
- Requires Bi-Amplification via PRO Loudspeaker Controllers
- **PRO PIVOT AIMING BRACKETS INCLUDED**



DESCRIPTION

The SR-12ai is a specialized version of the S-12sm designed to bring the experience of our powerful surface mount loudspeaker to a space-conscious environment. Utilizing the same 12" woofer and 1" wide-bandwidth compression driver found in its sibling, the SR-12ai differs only in form. Its unique elongated enclosure is designed for built-in installation, complete with mounting points and hardware to secure it to surrounding studs. A removable front baffle and quick-connect wiring harness allow the SR-12ai to be installed in stages. At only 7.5" deep, it requires minimal build out; making it the perfect solution for shallow screen channel or high-end effects channel applications.

Performance is provided by two high-sensitivity professional-grade drivers. The 12" woofer employs a massive motor system and 4" voice coil to maximize thermal power handling, resulting in bass that is tight and articulate while allowing the SR-12ai to play at sustained loud sound pressure levels without fear of the harsh distortion associated with traditional loudspeaker designs. Equally refined as powerful, the unique elliptical horn and wide-bandwidth compression driver provide linear dispersion of high-frequency energy to beyond 24kHz with true-to-life dynamic range.

Developed as part of an integrated digital cinema system, the SR-12ai and companion PRO loudspeaker controller employ advanced Digital Signal Processing (DSP) to optimize system performance. As in commercial cinema systems, the SR-12ai is bi-amplified, maximizing performance of each driver. With maximum output exceeding 130dB, it is ideal for use in any application where loudspeaker depth limitations may be a concern.

SPECS

APPLICATION:	Bi-amplified architectural format screen or surround channel loudspeaker
LF SECTION:	12" professional grade woofer with 4" voice coil
HF SECTION:	1" professional-grade compression driver / polymer diaphragm 80° x 60° elliptical horn
CROSSOVER:	8th order acoustic via DSP
POWER HANDLING:	1400W LF / 120W HF
SENSITIVITY:	93dB LF / 108dB HF
POWER REQUIREMENTS:	Requires bi-amplification via PRO loudspeaker controller
POWER RECOMMENDATION:	450W LF / 200W HF
FREQUENCY RANGE:	40Hz – 24kHz
MAXIMUM OUTPUT:	>130dB
NOMINAL IMPEDANCE:	4-ohms LF / 8-ohms HF
DIMENSIONS:	36"H x 14"W x 7.5"D
WEIGHT:	51 lbs.

S-12sm Loudspeaker

KEY FEATURES

- Professional 12-inch, 1400W Woofer with 4-inch Voice Coil
- Professional 1.7-inch Ultra-Purity™ Compression Driver on Elliptical Wide Dispersion Horn
- High-Sensitivity: 93dB LF; 108dB HF
- Wide Bandwidth from a Compact Enclosure: 38Hz-22kHz, -6dB
- Maximum Output: 128dB
- State-of-the-art technical performance via PRO Loudspeaker Controller
- 4-ohm Nominal Impedance LF; 8-ohms HF
- Requires PRO Loudspeaker Controller (2 output channels)
- **PRO Pivot Aiming Bracket Compatible**

APPLICATIONS

- Surround Sound/Home Theater
- Studio Reference Monitor
- Two-Channel Stereo



DESCRIPTION

The S-12sm is the first in the new “S” series loudspeakers from Pro Audio Technology - objectively and subjectively the finest loudspeakers the company has ever produced.

The S-12sm is a medium format multipurpose loudspeaker designed for ultimate accuracy, resolution and unrestricted dynamics. Though compact in size, the S-12sm produces surprisingly full-range, visceral sound typically only found in much larger loudspeakers. The S-12sm’s unique elliptical horn and wide-bandwidth Ultra-Purity™ high-frequency compression driver provide ideal dispersion of high-frequency energy. The sound is clean, pure and coherent with no trace whatsoever of compression driver harshness.

Developed as part of an integrated digital system, the S-12sm’s companion PRO Loudspeaker Controller employs proprietary Digital Signal Processing (DSP) for high-resolution frequency response contouring, dynamics processing and critical time alignment. As in commercial and professional audio systems, the S-12sm is bi-amplified to maximize the performance of each driver in the system. With maximum output exceeding 130dB, it is the ideal choice for screen channel or reference applications in small, medium, and large sized rooms where loudspeaker size limitations might be a concern.

The subjective and measured performance of the S-12sm is so good it can be successfully used as a reference monitor in studios and other applications where absolute accuracy and high resolution are required.

SPECS

APPLICATION:	Bi-amplified medium format multipurpose loudspeaker
LF SECTION:	12” professional grade woofer with 4” voice coil
HF SECTION:	1.7” professional-grade compression driver with advanced polymer diaphragm on 80° x 60° elliptical horn
CROSSOVER:	8th order acoustic via DSP
POWER HANDLING:	1400W LF / 100W HF
SENSITIVITY:	93dB LF / 108dB HF
POWER REQUIREMENTS:	Bi-amplification via PRO Amplified Loudspeaker Controller
POWER RECOMMENDATION:	700W LF / 200W HF
WIRING REQUIREMENTS:	4 conductors
FREQUENCY RANGE:	38Hz – 22kHz, -6dB
MAXIMUM OUTPUT:	128dB
NOMINAL IMPEDANCE:	4-ohms LF / 8-ohms HF
DIMENSIONS:	25”H x 14”W x 12”D
WEIGHT:	63 lbs.

S-12sm Measurements

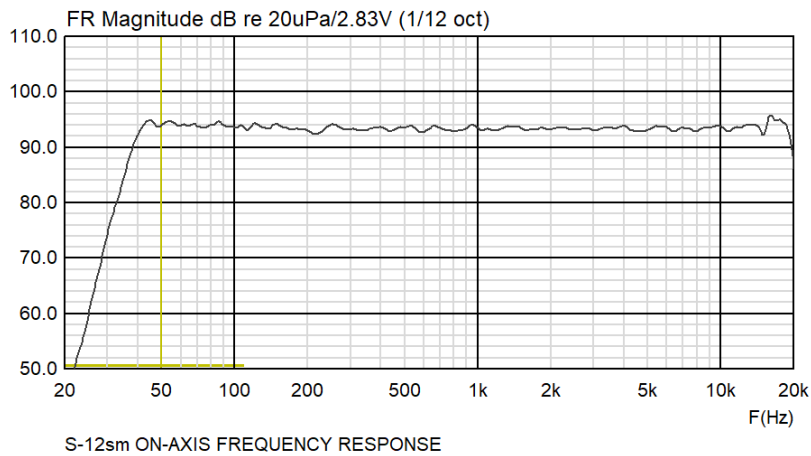

ON-AXIS FREQUENCY RESPONSE

The on-axis frequency response tells us the most about a loudspeaker's performance. An ideal response would be a horizontal straight line.

The S-12sm frequency response is remarkably flat and smooth, offering state of the art sonic performance. The response shown is unsmoothed.

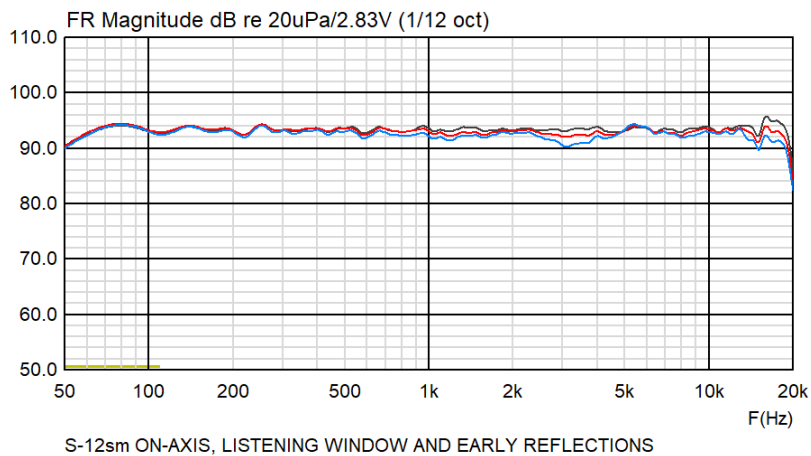

ON-AXIS, LISTENING WINDOW and EARLY REFLECTIONS RESPONSE

The "Listen Window" (red) is defined as the average of +/- 30 degrees off-axis horizontal and +/- 10 degrees vertical responses and represents what most listeners 'hear' when sitting in the listening area. "Early Reflections" (blue) response is defined as the average of responses +/- 90 degrees horizontal, 20-40 degrees down, and 40-60 degrees up and represents the frequency content of the sound bouncing off the side walls, floor and ceiling. Ideally, the "Early Reflections" and "Listening Window" would mimic the on-axis response of the loudspeaker.

The S-12sm Listening Window and Early Reflections responses are exemplary.

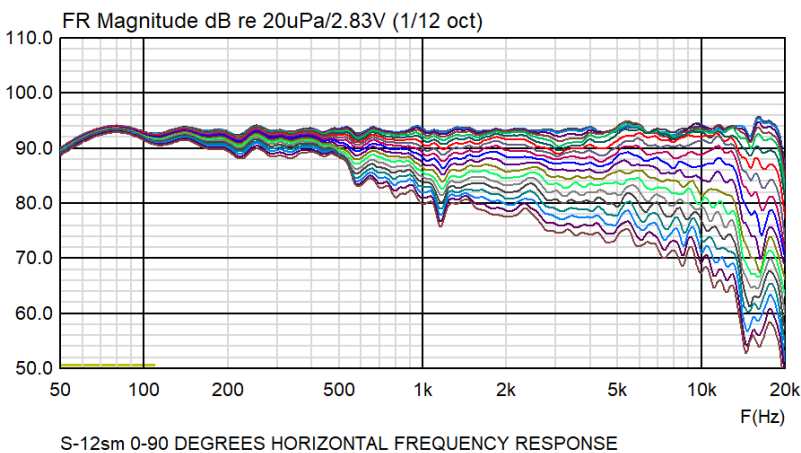

0-90 DEGREES OFF-AXIS RESPONSE

The off-axis frequency response is the second most important measurement of a loudspeaker's performance. An ideal response would be a horizontal straight line on-axis with a uniform and gradual fall off at the higher frequencies as you move off axis.

The S-12sm off-axis response is remarkably uniform and smooth as you move farther off-axis, offering state of the art sonic performance with dense, pinpoint stereo imaging.

S-12sm Measurements (con't)

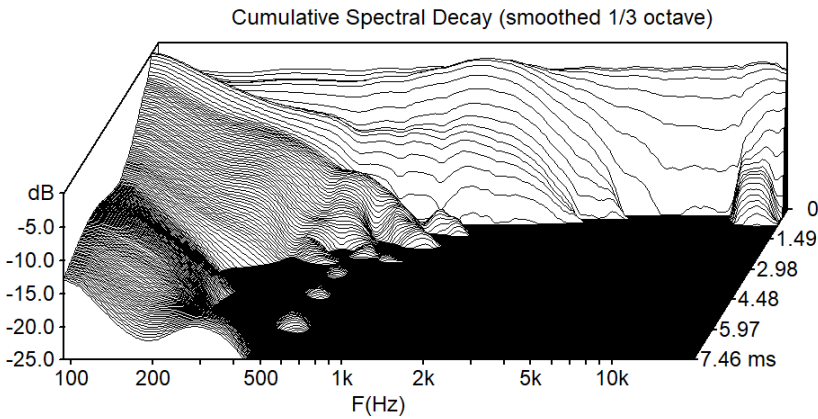

S-12sm CUMULATIVE SPECTRAL DECAY

ON-AXIS CUMULATIVE SPECTRAL DECAY

The on-axis Cumulative Spectral Decay or “Waterfall” plot reveals resonances within a system. An ideal response would be a horizontal straight line at time=0 (the back of the plot window).

The S-12sm Waterfall is remarkably clean and smooth, showcasing the remarkably clean and resonance-free performance of the Ultra-Purity™ compression tweeter.

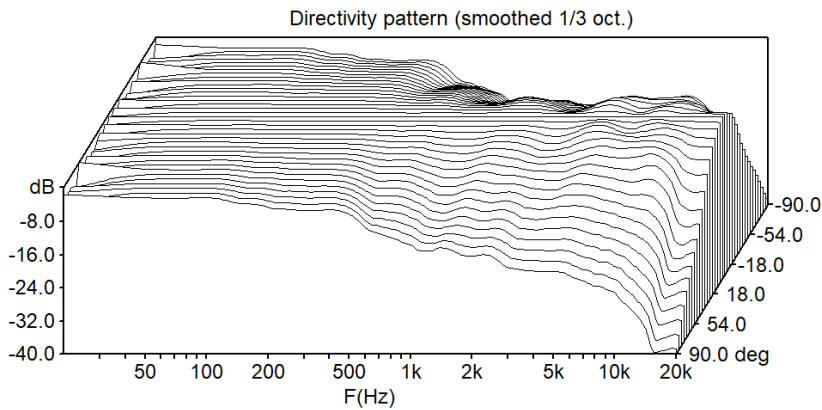

S-12sm LATERAL RESPONSE FAMILY

0-90 DEGREE OFF-AXIS WATERFALL PLOT

The “Off-Axis Waterfall Plot” or “Lateral Response Family” depicts the response of the loudspeaker at progressively more off-axis angles normalized to the on axis response. This shows how the sound “changes” when you’re not sitting directly on-axis and also give a good view of the coherence of the reflected energy in the room. An ideal response would be smooth gradual fall off of acoustic energy with rising frequency (left to right on the plot) and angle (front to back on the plot).

The S-12sm exhibits text book response with uniform, controlled dispersion all the way to 90 degrees off axis.

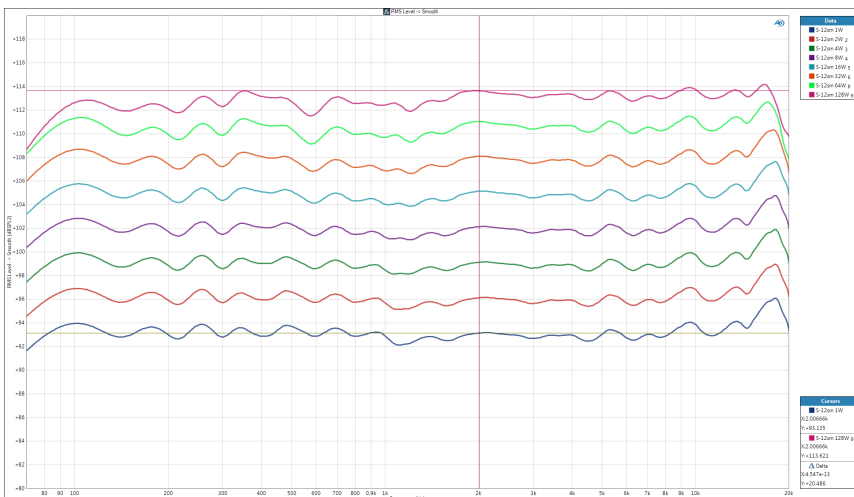

POWER COMPRESSION

The Power Compression plot characterizes the dynamic range of the loudspeaker, or how loudly it can play before it starts to thermally limit output. Each measurement is taken with +3dB greater input signal than the previous measurement. An ideal loudspeaker would show exactly 3dB spacing between all the curves.

The S-12sm is remarkable in this regard, showing only 0.5dB of “compression” at 128W at 114dB SPL at 1 meter distance.

S-12sm Dimensions

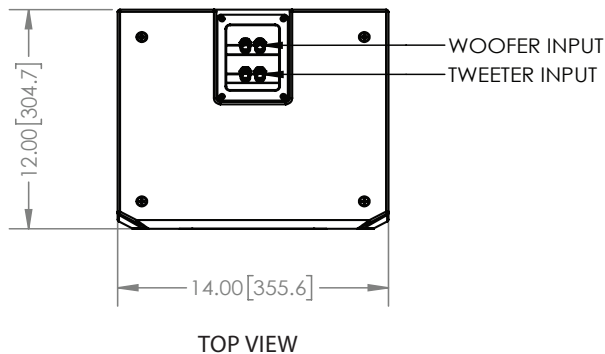

DIMENSIONS and FEATURES

The S-12sm requires bi-amplification via a PRO Amplified Loudspeaker Controller (ALC) therefore there are two sets of input terminals, one for the woofer and one pair for the tweeter. 4 conductors are required to make these connections.

Like all PRO S Series loudspeakers, the S-12sm has #1/4-20 mount points that can be used with optional PRO Pivot Mount Brackets.

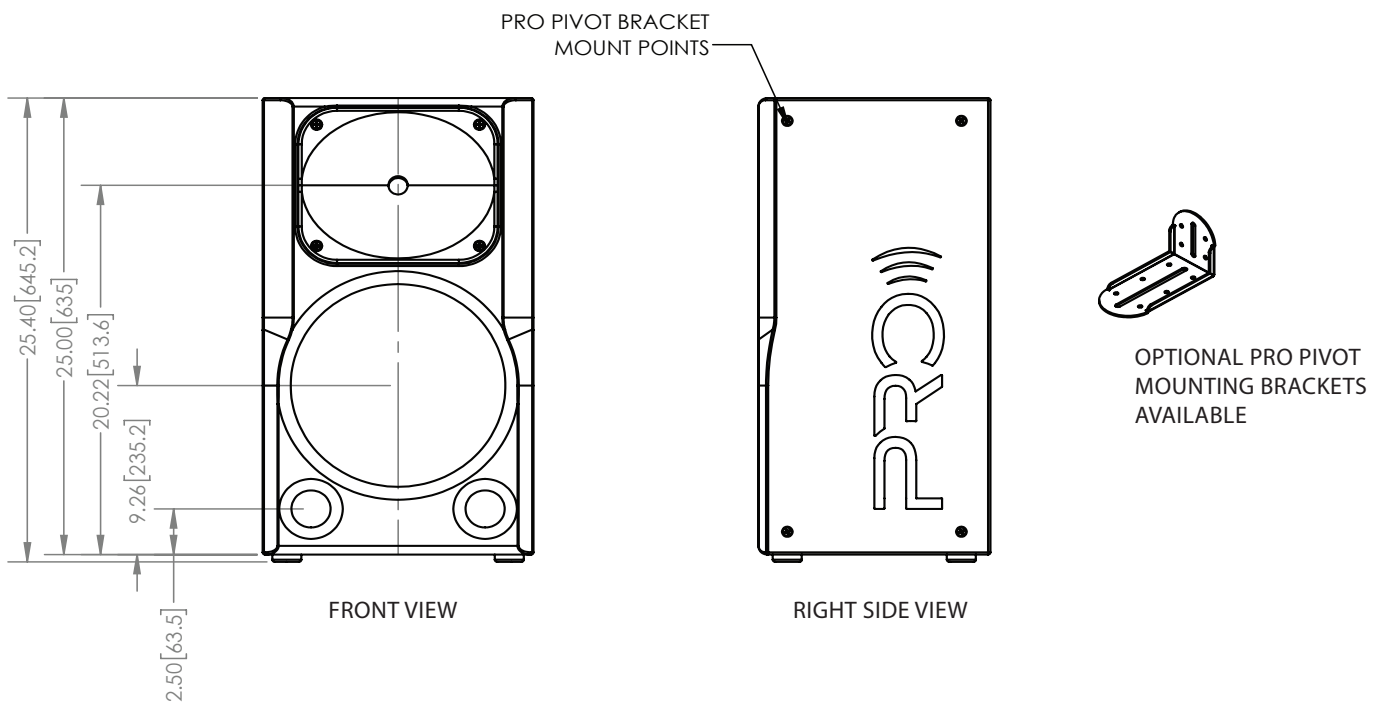

10-YEAR LIMITED LOUDSPEAKER WARRANTY

Professional Home Cinema, LLC dba "Pro Audio Technology" (PHC) guarantees its loudspeaker products to be free from defective materials and/or workmanship for a period of ten (10) years from the date of manufacture, and will replace defective parts and repair malfunctioning products under this warranty when the defect occurs under normal installation and use. This warranty does not extend to any product which has been subject to misuse, neglect, accident, improper installation - *including the use of PRO loudspeakers with 3rd-party amplification* - or where the date code has been removed or defaced. For more information please see www.proaudiotechnology.com.

CONTACT

PRO AUDIO TECHNOLOGY
25741 Atlantic Ocean Drive, Suite B
Lake Forest CA 92630

Telephone: 949.600.8250
Email: admin@proaudiotechnology.com
Web: www.proaudiotechnology.com



SCRS-8ai Loudspeaker

KEY FEATURES

- Architectural Installation™ Cabinet Design: 7-inch Total Depth for Easy Built-In Installation
- Professional 8-inch 400W Woofer with Neodymium Motor System
- Professional 1-inch Compression Driver on Elliptical Constant Directivity Horn
- High-Frequency Extension to Beyond 30kHz
- Designed for Placement Behind Acoustically Transparent Screen
- 8th Order Crossover Slopes
- High-Sensitivity Design: 94dB LF / 114dB HF
- Maximum Output: 118dB
- 8-ohm Nominal Impedance
- DSP Performance Optimized
- Requires Bi-Amplification via PRO Loudspeaker Controllers



DESCRIPTION

The SCRS-8ai is a compact high-output loudspeaker. Its installation-friendly enclosure includes integrated pick points and mounting hardware to secure the speaker to surrounding framing. A removable front baffle and quick-connect wiring harness allow the SCRS-8ai to be installed in stages, assuring safety of the drivers during theater room construction. At only 7" deep, it requires minimal build out; making the SCRS-8ai the perfect solution when performance is demanded, but space is at a premium.

Using high-output professional-grade components, the SCRS-8ai creates a big, dynamic sound far surpassing the performance limitations of traditional home audio loudspeakers. Its 8" woofer employs a neodymium motor system with oversized voice coil to maximize thermal power handling. Bass is powerful and articulate, resolving fine textures and subtle details with ease. In like manner, a high-sensitivity compression driver and unique elliptical horn provide linear dispersion of high-frequency energy to beyond 30kHz with true-to-life dynamic range. Seamless integration of the drivers results in one coherent voice, enhancing the vocal intelligibility so important in home theater applications.

Developed as part of an integrated digital cinema system, the SCRS-8ai and companion PRO loudspeaker controller are equally adept at screen channel or effects channel applications. As in commercial cinema installations, the SCRS-8ai is bi-amplified to maximize the performance of each driver in the system. Proprietary Digital Signal Processing (DSP) is employed for high-resolution frequency shaping and time alignment. Maximum output is 118dB; making the SCRS-8ai an exceptional choice for medium-sized and small room installations.

SPECS

APPLICATION:	Bi-amplified architectural format screen or surround channel loudspeaker
LF SECTION:	8" professional grade woofer with 2" voice coil / Neodymium motor
HF SECTION:	1" professional-grade compression driver / polyester diaphragm 80° x 60° elliptical horn
CROSSOVER:	8th order acoustic via DSP
POWER HANDLING:	400W LF / 120W HF
SENSITIVITY:	94dB LF / 114dB HF
POWER REQUIREMENTS:	Requires bi-amplification via PRO loudspeaker controllers
POWER RECOMMENDATION:	450W LF / 200W HF
FREQUENCY RANGE:	58Hz – 31kHz
MAXIMUM OUTPUT:	118dB
NOMINAL IMPEDANCE:	8-ohms LF / 8-ohms HF
DIMENSIONS:	18"H x 14"W x 7"D
WEIGHT:	22 lbs.

SR-26im Loudspeaker

KEY FEATURES

- Professional 6-inch 260W Woofers (2) with Neodymium Motor Systems
- Professional 1-inch Compression Driver on Elliptical Constant Directivity Horn
- Invisible Mount Modular Enclosure Design
- Designed for Installation in 2 x 4 Stud Bay
- 8th Order Crossover Slopes
- High Sensitivity Design: 96dB LF / 107dB HF
- Maximum Output: 122dB
- 4-ohm Nominal Impedance
- DSP Performance Optimized
- Requires Bi-Amplification via PRO Loudspeaker Controller
- **PRO PIVOT AIMING BRACKET COMPATIBLE**



DESCRIPTION

The SR-26im was conceived as a high-performance in-wall solution capable of providing the dynamics and high SPL levels for which PRO loudspeakers have become widely celebrated. Its innovative shallow enclosure fits neatly into a 2 x 4 stud bay while delivering a nearly undetectable designer-friendly installation when finished with its bezel-less perforated metal grille. Paintable, and fitting nearly flush to the sheetrock, the SCRS-26im cleanly disappears into its surroundings.

More impressive than its novel installation design is the sound produced by the SR-26im. Using high-output professional-grade components, the speaker creates a big, dynamic sound far surpassing the performance limitations of in-wall loudspeakers systems. A ported speaker design, its dual 6" professional-grade woofers employ powerful neodymium motor systems, resulting in bass that is tight, extended, and articulate. Likewise, its high-sensitivity compression driver and proprietary elliptical horn provide linear dispersion of high-frequency energy to beyond 24kHz, producing silky smooth highs with true-to-life dynamic range.

The SR-26im is suitable for use as a screen or surround channel loudspeaker in high-performance theater installations, as well as for high-resolution distributed audio systems. Like other PRO designs, it requires bi-amplification, maximizing the performance of each driver in the system. When mated to its companion PRO loudspeaker controller, proprietary Digital Signal Processing (DSP) is employed for high-resolution frequency shaping, boundary effects correction, and driver time alignment. Maximum output is 122dB; making the SR-26im the ultimate choice for all in-wall loudspeaker applications.

SPECS

APPLICATION:	Built-in in-wall high-output bi-amp speaker with frameless grille
LF SECTION:	Two professional 6.5" long-throw woofer
HF SECTION:	Professional 1" compression driver on 90° x 60° elliptical horn
CROSSOVER:	8th order acoustic via DSP
POWER HANDLING:	560W LF / 120W HF
SENSITIVITY:	96 dB LF/ 107dB HF
POWER REQUIREMENTS:	Requires bi-amplification via PRO loudspeaker controller
POWER RECOMMENDATION:	200W, 300W or 450W LF 100W or 200W HF
FREQUENCY RANGE:	54Hz – 24kHz
MAXIMUM OUTPUT:	122dB
NOMINAL IMPEDANCE:	4-ohms LF / 8-ohms HF
DIMENSIONS:	30"H x 14"W x 3-3/8"D (enclosure)
WEIGHT:	24 lbs.

SR-26im Measurements

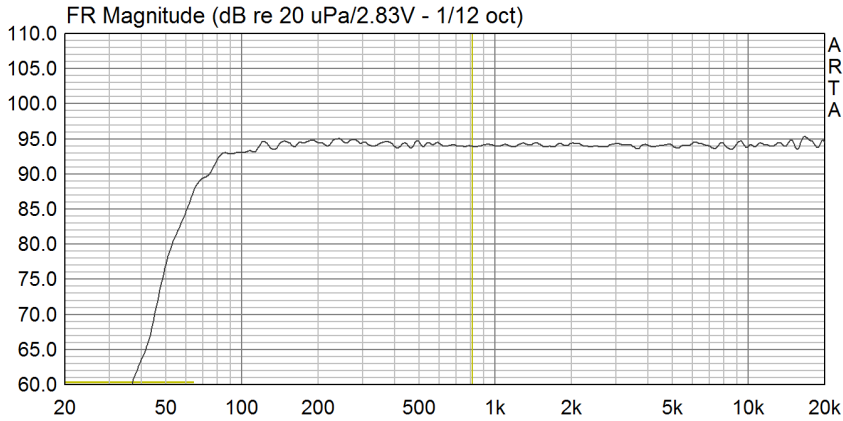

ON-AXIS FREQUENCY RESPONSE

The on-axis frequency response tells us the most about a loudspeaker's performance. An ideal response would be a horizontal straight line.

The SR-26im frequency response is remarkably flat and smooth, offering state of the art sonic performance. The response shown is unsmoothed.

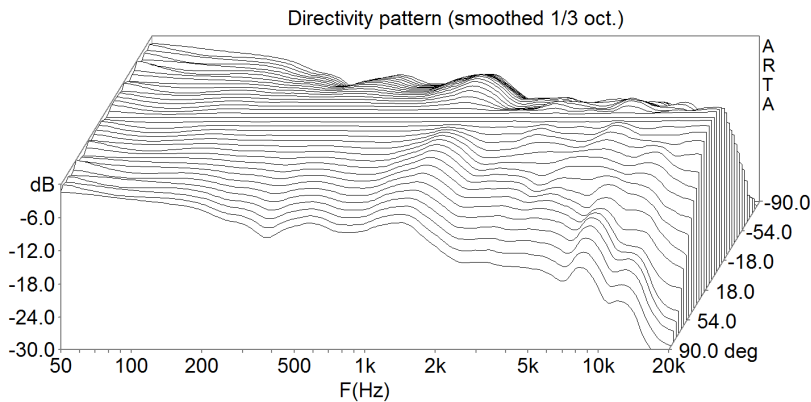

0-90 DEGREE OFF-AXIS WATERFALL PLOT

The "Off-Axis Waterfall Plot" or "Lateral Response Family" depicts the response of the loudspeaker at progressively more off-axis angles normalized to the on axis response. This shows how the sound "changes" when you're not sitting directly on-axis and also give a good view of the coherence of the reflected energy in the room. An ideal response would be smooth gradual fall off of acoustic energy with rising frequency (left to right on the plot) and angle (front to back on the plot).

The SR-26im exhibits uniform, controlled dispersion all the way to 90 degrees off axis.

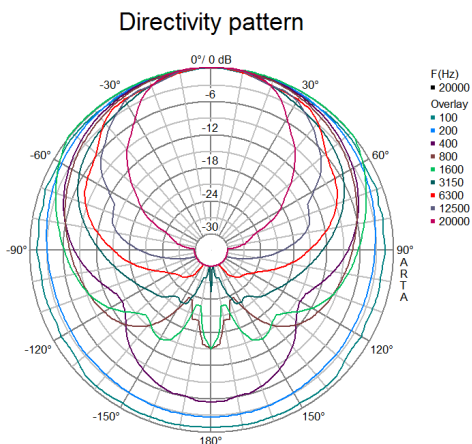

$$f = 20000 \text{ Hz}, Q = 3.59, DI = 5.5 \text{ dB}, \text{Angle}(-6\text{dB}) = 62.4^\circ$$

0-180 POLAR RESPONSE

The Polar Response plots the off-axis dispersion of the speaker at discrete frequencies on a 360-degree polar "map". Amplitude is shown concentric circles with 0dB (reference level) at the outer ring with decreasing amplitude toward the center of the circular plot. 0 degrees is the main axis.

Beamwidth is defined as the angular dispersion that occurs 6dB below on-axis response. It can be seen from the plot that the Beamwidth of the SR-26im is a very wide 100 degrees at 12.5kHz. The sound is extended and "open" up to the very highest audio frequencies.

SR-6im/SR-6im-P Loudspeaker

KEY FEATURES

- Compact Version of SR-26im
- Ported Enclosure Included
- Fits Within 2" x 4" Wall
- Passive (SR-6im-P) and Bi-Amp (SR-6im) Versions
- Ideal for Dolby Atmos and Auro 3D
- Low Profile Surface Mount Grille Available
- **PRO PIVOT AIMING BRACKET COMPATIBLE**



DESCRIPTION

The SR-6im in-wall loudspeaker is the new "little brother" to the best-selling SR-26im model. The SR-6im offers the same dynamic and accurate sound quality of the 26im but at a lower cost and can be purchased with optional passive crossover network (SR-6im-P) for single-amp operation.

The SR-6im (with tuned bass-reflex enclosure) is less than 4" deep and 14" wide to fit within standard 2" x 4" architectural walls. An optional surface-mount, minimum-frame perforated grille is available.

Like the SR-26im, the SR-6im creates a big, dynamic sound far surpassing the performance limitations of in-wall loudspeakers systems. Its 6" professional-grade woofer employs a powerful neodymium motor system, resulting in bass that is tight, extended, and articulate. In like manner, its high-sensitivity compression driver and proprietary elliptical horn provide linear dispersion of high-frequency energy to beyond 24kHz, producing silky smooth highs with true-to-life dynamic range.

The SR-6im is suitable for use as either a screen or surround channel loudspeaker in high-performance theater installations, as well as for high-end two-channel and distributed audio systems where aesthetics are a concern. The SR-6im has been designed for bi (SR-6im) or single amplification (SR-6im-P) to provide greatest system design flexibility. Maximum output is 116dB; making the SR-6im the ultimate choice for all in-wall loudspeaker applications.

SPECS

APPLICATION:	Built-in, in-wall, high-output two way bi or single amp loudspeaker
LF SECTION:	Professional 6" long-throw woofer
HF SECTION:	Professional 1" compression driver on 90 x 60 Elliptical horn
CROSSOVER:	8th order acoustic via DSP
POWER HANDLING:	280W LF / 120W HF
SENSITIVITY:	93dB LF / 107dB HF
POWER REQUIREMENTS:	Requires amplification via PRO loudspeaker controller
POWER RECOMMENDATION:	300W or 450W LF / 100W or 200W HF / 300W or 450W Passive
FREQUENCY RANGE:	58Hz -24kHz
MAXIMUM OUTPUT:	116dB
NOMINAL IMPEDANCE:	8-ohms
DIMENSIONS:	26"H x 14"W x 3.9"D
WEIGHT:	21 lbs.

SR-6im/SR-6im-P Measurements

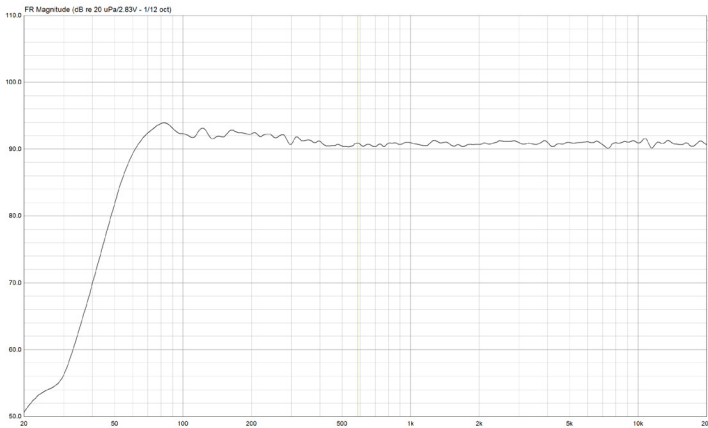

ON-AXIS FREQUENCY RESPONSE

The on-axis frequency response tells us the most about a loudspeaker's performance. An ideal response would be a horizontal straight line.

The SR-6im/SR-6im-P frequency response is remarkably flat and smooth, offering state of the art sonic performance. The response shown is unsmoothed.

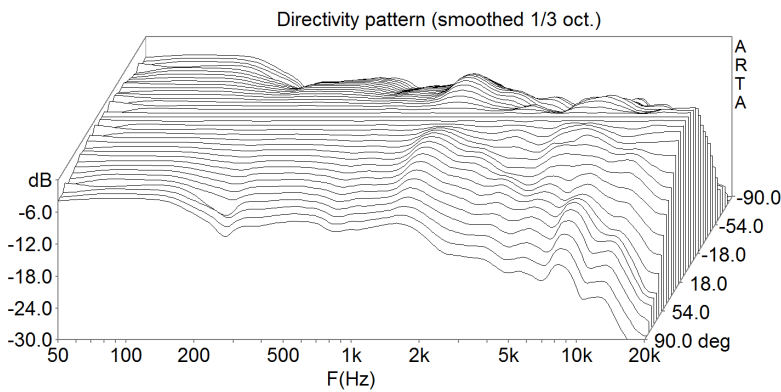

0-90 DEGREE OFF-AXIS WATERFALL PLOT

The "Off-Axis Waterfall Plot" or "Lateral Response Family" depicts the response of the loudspeaker at progressively more off-axis angles normalized to the on axis response. This shows how the sound "changes" when you're not sitting directly on-axis and also give a good view of the coherence of the reflected energy in the room. An ideal response would be smooth gradual fall off of acoustic energy with rising frequency (left to right on the plot) and angle (front to back on the plot).

The SR-6im/SR-6im-P exhibits uniform, controlled dispersion all the way to 90 degrees off axis.

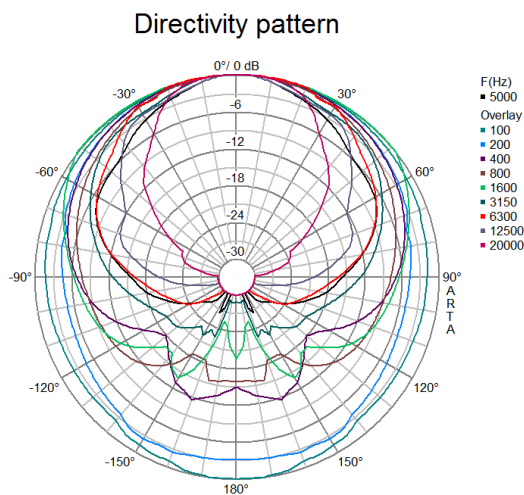

0-180 POLAR RESPONSE

The Polar Response plots the off-axis dispersion of the speaker at discrete frequencies on a 360-degree polar "map". Amplitude is shown concentric circles with 0dB (reference level) at the outer ring with decreasing amplitude toward the center of the circular plot. 0 degrees is the main axis.

Beamwidth is defined as the angular dispersion that occurs 6dB below on-axis response. It can be seen from the plot that the Beamwidth of the SR-6im/SR-6im-P is a very wide 100 degrees at 12.5kHz. The sound is extended and "open" up to the very highest audio frequencies.

SCRS-6iw / 6iw-P Loudspeaker

KEY FEATURES

- Professional 6-inch 260W Woofer with Neodymium Motor System
- Professional 1-inch Compression Driver on Elliptical Constant Directivity Horn
- Invisible Mount Design
- Designed for Retrofit Installation
- High-Frequency Extension to beyond 30kHz
- 8th Order Crossover Slopes
- High-Sensitivity Design: 93dB LF / 114dB HF
- Maximum Output: 116dB
- 8-ohm Nominal Impedance
- DSP Performance Optimized
- Available in Bi-Amped (SCRS-6iw) or Single-Amped (SCRS-6iw-P) Versions



DESCRIPTION

The SCRS-6iw makes the high-output capabilities of the PRO loudspeaker line accessible to all with an easy-to-integrate retrofit in-wall design. Using high-output professional-grade components, the speaker creates a big, dynamic sound far surpassing the performance limitations of in-wall loudspeakers systems. Its 6" professional-grade woofer employs a powerful neodymium motor system, resulting in bass that is tight, extended, and articulate. In like manner, its high-sensitivity compression driver and proprietary elliptical horn provide linear dispersion of high-frequency energy to beyond 30kHz, producing silky smooth highs with true-to-life dynamic range.

The SCRS-6iw is suitable for use as either a screen or surround channel loudspeaker in high-performance theater installations. Likewise, it is perfectly suited for distributed audio systems where large floor standing loudspeakers are deemed undesirable, but expectations exceed the performance limitations offered by traditional in-wall loudspeaker solutions.

Like other PRO loudspeakers, the SCRS-6iw has been designed for bi-amplification to maximize the performance of each driver in the system. However, when budget constraints dictate, it can also be purchased with an integrated passive crossover network (model SCRS-6iw-P) allowing the speaker to be driven by a single loudspeaker controller channel. In either mode of operation, proprietary Digital Signal Processing (DSP) is employed for high resolution frequency response shaping, boundary effects correction, and driver time alignment. As such, PRO amplification is required. Maximum output is 116dB; making the SCRS-6iw the ultimate choice for all in-wall loudspeaker applications.

SPECS

APPLICATION:	In-wall high-output bi-amp speaker with frameless grille
LF SECTION:	Professional 6.5" long-throw woofer
HF SECTION:	Professional 1" compression driver on 90° x 60° elliptical horn
CROSSOVER:	8th order acoustic via DSP
POWER HANDLING:	260W LF / 120W HF
SENSITIVITY:	93dB LF / 114dB HF
POWER REQUIREMENTS:	Requires bi-amplification via PRO loudspeaker controllers
POWER RECOMMENDATION:	200W, 300W or 450W LF 100W or 200W HF 200W, 300W or 450W Passive
FREQUENCY RANGE:	52Hz – 31kHz
MAXIMUM OUTPUT:	116dB
NOMINAL IMPEDANCE:	8-ohms LF / 8-ohms HF
DIMENSIONS:	13-7/8"H x 8-7/8"W x 3-1/4"D
CUTOUT DIMENSIONS:	12-7/8"H x 7-7/8"W
WEIGHT:	8 lbs.

SCRS-6c-iw Loudspeaker

KEY FEATURES

- 6-inch Two-Way Loudspeaker, Only 8-inch Square
- High-Sensitivity: 93dB LF / 105dB HF
- 4-inch Deep Back Box Included
- Ideal for Dolby Atmos Systems
- Input Cover with Conduit Termination
- All Metal Construction
- Superb for Distributed Audio
- Requires Amplification (single channel) via PRO Loudspeaker Controller



DESCRIPTION

The SCRS-6c-iw brings PRO trademark thrilling sound to Immersive and Distributed Audio systems at a new level of affordability. Though compact at 8" square and only 3.9" deep, the SCRS-6c-iw is a true high-output design. The 6.5" professional-grade driver features a common magnet for both the high-output woofer and coaxially-mounted, high-sensitivity compression tweeter. This unique magnet design keeps driver depth to a minimum, allowing the SCRS-6c-iw to fit comfortably into a standard 2"x4" stud construction wall.

The SCRS-6c-iw is highly efficient (unheard of for architectural speakers) with sensitivities of 93dB and 103dB per 1 watt input for the woofer and compression tweeter respectively. The result is sound which is lively, with high dynamic contrast and full bandwidth even at low listening levels. The SCRS-6c-ica includes a passive crossover network so it can be driven with a single amplifier channel, but like all PRO loudspeakers, it requires a PRO DSP amplifier for high pass-filtration and response contouring.

While the dynamic capability of this surprisingly small and affordable speaker makes it perfect for Surround and Immersive Audio systems in media or multi-use rooms, the SCRS-6c-iw also excels as a Distributed Audio speaker throwing full and rich sound in a very wide 100 degree pattern. You can easily cover large rooms with fewer loudspeakers.

To achieve the high sensitivity, the SCRS-6c-iw sacrifices a bit of low-frequency bandwidth, so it must be used in conjunction with Surround or Distributed Audio subwoofers.

SPECS

APPLICATION:	In-wall, high-output compact full-range speaker with grille
LF SECTION:	6" high-output woofer
HF SECTION:	1" compression driver on concentric horn
CROSSOVER:	8th order acoustic via DSP
POWER HANDLING:	150W
SENSITIVITY:	93dB
POWER REQUIREMENTS:	Requires amplification via PRO DSP amplifier
POWER RECOMMENDATION:	100W, 200W or 300W
FREQUENCY RANGE:	125Hz -23kHz
MAXIMUM OUTPUT:	113db
NOMINAL IMPEDANCE:	8-ohms
DIMENSIONS:	8"H x 8"W x 3.9"D
WEIGHT:	7.3 lbs.

SCRS-6c-ica Loudspeaker

KEY FEATURES

- 6-inch Two-Way Loudspeaker, Only 8-inch Square
- High-Sensitivity: 93dB LF / 105dB HF
- 6-inch Deep Back Box Included
- Ideal for Dolby Atmos Systems
- Angled Version of the SCRS-6c-iw
- All Metal Construction
- Input Cover with Conduit Termination
- Requires Amplification (single channel) via PRO Loudspeaker Controller



DESCRIPTION

The SCRS-6c-ica is an angled version of the SCRS-6c-iw and is perfect for Immersive Audio ceiling and surround applications that require the loudspeakers to be "aimed" at the listening area. Like its "iw" cousin, the SCRS-6c-ica brings PRO trademark thrilling sound to Immersive and Distributed Audio systems at a new level of affordability. Though compact at 8" square and only 5.75" deep, the SCRS-6c-ica is a true high-output design. The 6.5" professional-grade driver features a common magnet for both the high-output woofer and coaxially-mounted, high-sensitivity compression tweeter. This unique magnet design keeps driver depth to a minimum, allowing the angled SCRS-6c-ica to fit into a 2"x6" stud construction wall.

The SCRS-6c-ica is highly efficient (unheard of for architectural speakers) with sensitivities of 93dB and 103dB per 1 watt input for the woofer and compression tweeter respectively. The result is sound which is lively, with high dynamic contrast and full bandwidth even at low listening levels. The SCRS-6c-ica includes a passive crossover network so it can be driven with a single amplifier channel, but like all PRO loudspeakers, requires a PRO DSP amplifier for high pass-filtration and response contouring.

To achieve the high sensitivity, the SCRS-6c-ica sacrifices a bit of low-frequency bandwidth, so it must be used in conjunction with Surround or Distributed Audio subwoofers. It partners perfectly with the LFC-210im in-wall subwoofer system to create high-output, full-range distributed audio systems for foreground and background music applications.

SPECS

APPLICATION:	In-ceiling high-output angled compact full-range speaker with grille
LF SECTION:	6" high-output woofer
HF SECTION:	1" compression driver on concentric horn
CROSSOVER:	8th order acoustic via DSP
POWER HANDLING:	150W
SENSITIVITY:	93dB
POWER REQUIREMENTS:	Requires amplification via PRO DSP amplifier
POWER RECOMMENDATION:	100W, 200W or 300W
FREQUENCY RANGE:	125Hz - 23kHz
MAXIMUM OUTPUT:	113db
NOMINAL IMPEDANCE:	8-ohms
DIMENSIONS:	8"H x 8"W x 5.75"D
WEIGHT:	7.8 lbs.

SR-25im / SR-25im-P Loudspeaker

KEY FEATURES

- Quality European Professional-Grade Drivers
- True Compression HF Driver with Neodymium Motor System
- Dual High-power 5-inch woofers
- Shallow Profile Enclosure Fits a 2" x 4" Stud Bay
- Suitable for Screen Channel or Surround Channel Applications
- DSP Optimized Performance
- Optional Low-Profile Perforated Metal Grille Available
- Requires PRO Loudspeaker Controller
- Available in bi-amp or passive versions
- **PRO PIVOT AIMING BRACKET COMPATIBLE**



DESCRIPTION

The SR-25im and SR-25im-P (passive crossover version) is PRO's most affordable loudspeaker to date. But don't let its affordability fool you – the 25im models throw a highly resolved, tonally pure and remarkably refined sound with dynamic scale that will astonish. Like all PRO loudspeakers, the components used are professional-grade, high-power units sourced from Europe. A ¾" polymer compression driver is mated to a proprietary PRO waveguide to produce 109dB SPL from a single watt of power. High frequencies are rendered with liquidity, resolution and seemingly endless dynamic range. Two professional 5" woofers, employed in electrical parallel, provide 96dB/W sensitivity – remarkable for 5" drivers – and integrate flawlessly with the HF unit. The resulting sound is refined, dynamically robust and remarkably detailed.

The SR-25im models may be mounted within a 2"x4" wall with optional low-profile perforated metal grille, or can be mounted to the wall surface itself in applications where architectural details, or the perforated video screen will conceal the unit from view. The SR-25im and SR-25im-P are suitable for use in LCR and Surround applications, or as high-output in-ceiling ATMOS channels. The SR-25im models must be bass-managed to local or remote subwoofers at 80-100Hz and carry PRO's industry-leading 10 year warranty.

APPLICATION:	Built in, in-wall, high-output two-way bi or single amp loudspeaker
LF SECTION:	Dual 5" long-throw woofers
HF SECTION:	Professional 0.75" compression driver on 90° x 60° elliptical horn
CROSSOVER:	Included passive network or 8th-order via DSP in bi-amp mode
POWER HANDLING:	320W LF / 40W HF
SENSITIVITY:	96dB LF / 109dB HF
POWER REQUIREMENTS:	Requires PRO power amplifier with DSP
POWER RECOMMENDATION:	200W or 300W LF / 100W or 200W HF 100W, 200W, 300W Passive
FREQUENCY RANGE:	80Hz – 18kHz
MAXIMUM OUTPUT:	115dB
NOMINAL IMPEDANCE:	4-ohms LF / 8-ohms HF
DIMENSIONS:	16"H x 14"W x 3.4"D
WEIGHT:	15 lbs.

SR-25im/SR-25im-P Measurements

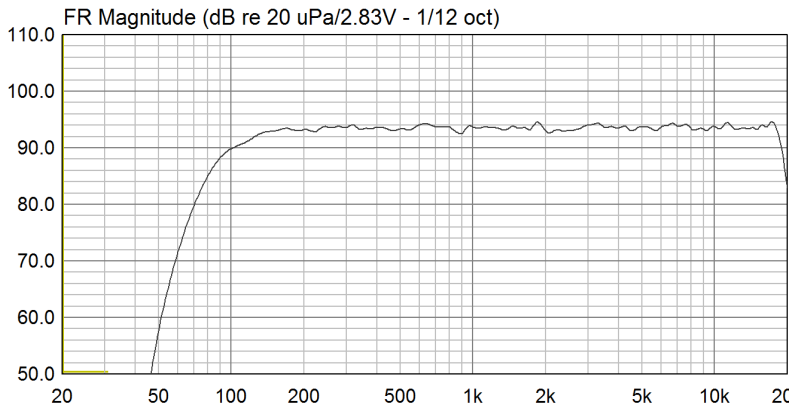

ON-AXIS FREQUENCY RESPONSE

The on-axis frequency response tells us the most about a loudspeaker's performance. An ideal response would be a horizontal straight line.

The SR-25im/SR-25im-P frequency response is remarkably flat and smooth, offering state of the art sonic performance. The response shown is unsmoothed.

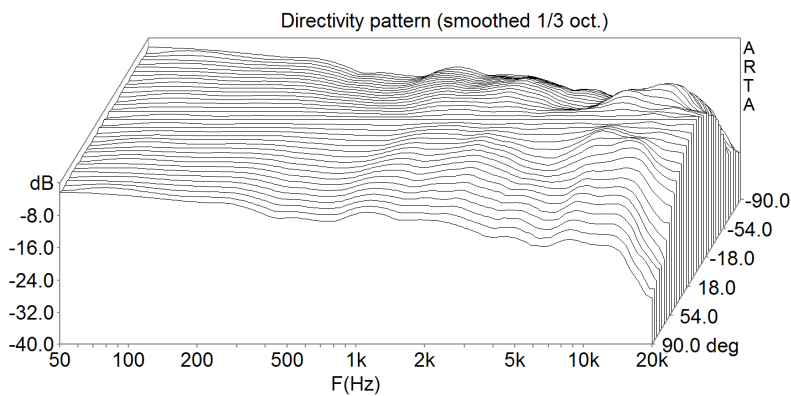

0-90 DEGREE OFF-AXIS WATERFALL PLOT

The "Off-Axis Waterfall Plot" or "Lateral Response Family" depicts the response of the loudspeaker at progressively more off-axis angles normalized to the on axis response. This shows how the sound "changes" when you're not sitting directly on-axis and also give a good view of the coherence of the reflected energy in the room. An ideal response would be smooth gradual fall off of acoustic energy with rising frequency (left to right on the plot) and angle (front to back on the plot).

The SR-25im/SR-25im-P exhibits uniform, and very wide yet controlled dispersion all the way to 90 degrees off axis.

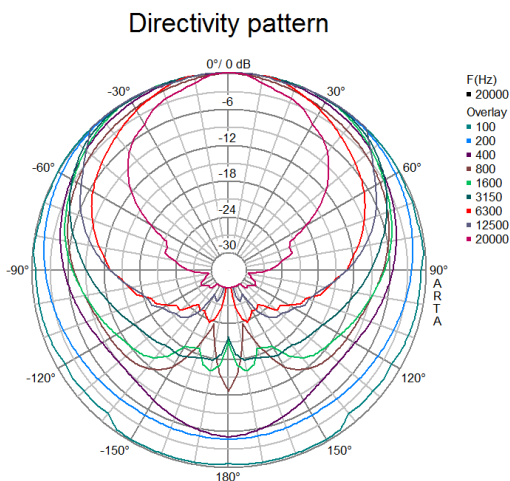

0-180 POLAR RESPONSE

The Polar Response plots the off-axis dispersion of the speaker at discrete frequencies on a 360-degree polar "map". Amplitude is shown concentric circles with 0dB (reference level) at the outer ring with decreasing amplitude toward the center of the circular plot. 0 degrees is the main speaker axis.

Beamwidth is defined as the angular dispersion that occurs 6dB below on-axis response. It can be seen from the plot that the Beamwidth of the SR-25im/SR-25im-P is more than 100 degrees at 12.5kHz. The sound is extended and "open" up to the very highest audio frequencies.

SCRS-25ica Loudspeaker

KEY FEATURES

- Angled In-Ceiling Design with Frameless Grill
- All Metal Construction
- Bi-Amp or Single-Amp Operation with Included Passive Crossover
- Integral Back Box
- True Compression HF Driver with Neodymium Motor System
- Dual High-Power, 5-inch Woofers
- High-Sensitivity / High-Output
- Perfect Companion for SCRS-5iw In-Wall Loudspeaker
- DSP Optimized Performance
- Requires PRO Loudspeaker Controller



DESCRIPTION

The SCRS-25ica in-ceiling loudspeaker brings PRO's signature high output levels and thrilling dynamics to installations where wall-mount or behind-the-screen speaker positioning is unavailable. Like all PRO loudspeakers, the SCRS-25ica employs professional-grade drivers, including a ¾" high frequency compression driver mounted on a proprietary horn and dual high-power 5" woofers. Together, these drivers produce dynamics and SPL levels that belie their size. The angled front baffle allows the speaker to be located in the ceiling near the viewing screen while directing the sound forward into the listening area. Though ceiling mounted, the SCRS-25ica casts large, full bodied images, presenting vocals and sound effects that are distinctly associated with the video image. An integrated passive crossover network permits the SCRS-25ica to operate with a single amp channel when cost effective applications demand high performance on a budget. However, easy to access connections allow the passive network to be bypassed for Bi-amp operation where the highest level of performance is required.

Designed for retrofit applications, the 25ica employs PRO's proprietary MonoClamp™ design. The speaker can be installed in a matter of seconds with nothing more than a Phillips screwdriver and will work in all types of home or commercial construction. The 25ica will fit, in either orientation, within 12" O.C. joists and is less than 8" deep. Any ceiling material thickness can be accommodated by simply changing the length of a few screws. Like all Pro Audio Technology loudspeakers, the SCRS-25ica requires PRO amplification as DSP is required in all operating modes.

SPECS

APPLICATION:	In-ceiling high-output bi or single amp speaker with frameless grille
LF SECTION:	Dual 5" long-throw woofers
HF SECTION:	Professional 0.75" compression driver on 90° x 60° elliptical horn
CROSSOVER:	Included passive network or 8th order via DSP in bi-amp mode
POWER HANDLING:	320W LF / 40W HF
SENSITIVITY:	96dB LF / 109dB HF
POWER REQUIREMENTS:	Requires PRO power loudspeaker controller with DSP
POWER RECOMMENDATION:	200W or 300W LF / 100W or 200W HF 100W, 200W or 300W Passive
FREQUENCY RANGE:	60Hz – 18kHz
MAXIMUM OUTPUT:	115 dB
NOMINAL IMPEDANCE:	4-ohms LF / 8-ohms HF
DIMENSIONS:	11.6"H x 11.6"W x 7.2"D (with grille and back box)
CUTOUT DIMENSIONS:	10.6"H x 10.6"W
WEIGHT:	13 lbs.

SCRS-5iw Loudspeaker

KEY FEATURES

- In-Wall Design with Frameless Grill
- All Metal Construction
- Bi-Amp or Single Amp Operation with Include Passive Crossover
- Integral Back Box
- Fits Standard 2 x 4 Stud Bay
- True Compression HF Driver with Neodymium Motor System
- High-Power 5-inch Woofer
- Perfect Companion for SCRS-25iwa In-Ceiling Loudspeaker
- DSP Optimized Performance
- Requires PRO Loudspeaker Controller



DESCRIPTION

The SCRS-5iw is the smallest Pro Audio Technology loudspeaker but don't let its diminutive size fool you: this is a true high-output, professional-style loudspeaker system that provides the startling dynamics for which PRO has become famous. The 5iw employs a genuine high frequency compression driver mounted on a proprietary horn along with a high-power 5" wide-band woofer. An integrated passive crossover allows the SCRS-5iw to operate with a single amp channel when performance is mandated, but budget constraints are a concern. Likewise, the SCRS-5iw can be reconfigured for bi-amp operation.

Designed for retrofit applications, the 5iw employs PRO's proprietary MonoClamp™ design which allows the speaker to be installed in a matter of seconds with nothing more than a Phillips screwdriver. Any wall material thickness can be accommodated by simply changing the length of two screws to meet the application. Like all Pro Audio Technology loudspeakers, the SCRS-5iw requires PRO amplification as DSP is required in all operating modes.

SPECS

APPLICATION:	In-wall high-output bi or single amp speaker with frameless grille
LF SECTION:	5" long-throw woofer
HF SECTION:	Professional 0.75" compression driver on 90° x 60° elliptical horn
CROSSOVER:	Included passive network or 8th order via DSP in bi amp mode
POWER HANDLING:	160W LF / 40W HF
SENSITIVITY:	91dB LF / 109dB HF
POWER REQUIREMENTS:	Requires PRO power amplifier with DSP
POWER RECOMMENDATION:	200W or 300W LF / 100W or 200W HF 100W, 200W or 300W Passive
FREQUENCY RANGE:	65Hz – 18kHz
MAXIMUM OUTPUT:	109dB
NOMINAL IMPEDANCE:	8-ohms LF / 8-ohms HF
DIMENSIONS:	11.5"H x 7.5"W x 3.9"D (with grille and back box)
CUTOUT DIMENSIONS:	10.4"H x 6.6"W
WEIGHT:	7 lbs.

LFC-10sm Subwoofer

KEY FEATURES

- Extreme Long-Throw, 10-inch Driver for High Output
- Compact Enclosure - Only 14" x 26" x 12"
- Trademark PRO Visceral Bass Impact from Small Enclosure
- Maximum Output: >110dB
- 4-ohm Nominal Impedance
- DSP Optimized Performance
- Requires PRO DSP Loudspeaker Controller



DESCRIPTION

The LFC-10sm was developed to provide trademark PRO visceral low bass output in a compact, easy-to-integrate package. An extremely long-throw 10" woofer is used in a compact enclosure with over-sized free-flow port to maximize acoustic output and power handling. The LFC-10sm is tuned via DSP to match the acoustic response of PRO's larger vented subwoofers. The result is the same visceral yet tight bass quality that users have come to expect from Pro Audio Technology, but in a compact, easy-to-integrate form factor.

To achieve the lofty goal of matching the performance character of its larger siblings, the LFC-10sm employs an ultra-rigid 10" driver with a fiber reinforced diaphragm. The superior cone stiffness allows the diaphragm to move as a perfect piston, even during periods of high excursion, assuring tight, impactful bass response. The massive rubber surround and double stacked magnet motor system provide exceptional control of the long-throw driver, allowing deep bass while preserving the dynamic slam of the most demanding sound effects or musical scores.

The LFC-10sm's compact enclosure is small enough to fit inconspicuously within any living décor and the 12" depth makes locating the subwoofer inside cabinets or millwork a breeze.

SPECS

APPLICATION:	Compact format subwoofer
LF SECTION:	10" ultra-long throw woofer
CROSSOVER:	8th order acoustic via DSP
POWER HANDLING:	1000W
SENSITIVITY:	90dB
POWER REQUIREMENTS:	Requires amplification via PRO power loudspeaker controller
POWER RECOMMENDATION:	300W, 450W or 1000W
FREQUENCY RANGE:	22Hz - 80Hz
MAXIMUM OUTPUT:	>110dB
NOMINAL IMPEDANCE:	4-ohms
DIMENSIONS:	26"H x 14"W x 12"D
WEIGHT:	57 lbs.

LFC-210im Subwoofer

KEY FEATURES

- Fits Within Standard 2" x 4" Wall
- High-Sensitivity: 93dB / 1W
- High Output Bass-Reflex Design
- Dual 10-inch Long-Throw Woofers
- Low-Profile Grille Available
- Requires PRO DSP Processor/Loudspeaker Controller



DESCRIPTION

The LFC-210im is the first subwoofer model to appear in the “invisible mount” (im) series of products from Pro Audio Technology. Like all im models, the LFC-210im can be mounted within a standard 2" x 4" architectural wall and can be finished with an optional low-profile, minimum-frame, perforated grille to completely disappear into the home environment.

The LFC-210im, at last, brings trademark PRO visceral-yet-tuneful subwoofer performance to the in-wall format. Unlike in-wall sub designs from other manufacturers, the LFC-210im is a true bass-reflex design allowing it to move more air, with greater efficiency and lower distortion. The result is powerful low frequency performance usually only possible from bulky, large format subwoofers.

At the heart of the LFC-210im lie two long-throw, carbon-fiber 10" woofers with equivalent radiating area of a single 14" woofer. Four total high-power voice coils (two per driver) insure high power handling and high efficiency. Combined with the precisely tuned bass-reflex enclosure, these drivers provide low frequency performance of startling quantity and quality.

With a maximum output of 114dB (in wall) the LFC-210im can be used as a primary or auxiliary subwoofer in a dedicated theater system, or as a (sub)woofer in high-output distributed audio applications.

SPECS

APPLICATION:	In-wall subwoofer
LF SECTION:	Dual 10" long-throw woofers
CROSSOVER:	8th order acoustic via DSP
POWER HANDLING:	500W
SENSITIVITY:	93dB
POWER REQUIREMENTS:	Requires amplification via PRO power amplifier
POWER RECOMMENDATION:	300W or 450W
FREQUENCY RANGE:	25Hz -125Hz
MAXIMUM OUTPUT:	114dB
NOMINAL IMPEDANCE:	4-ohms
DIMENSIONS:	84"H x 14"W x 3.9"D
WEIGHT:	59 lbs.

LFC-12v Subwoofer

KEY FEATURES

- Architectural Installation™ Cabinet Design: 6-inch Total Depth for Easy Built-In Installation
- Professional 12-inch, 700W driver with 4-inch Voice Coil
- High-Sensitivity: 96dB
- Enclosure Depth Integrates with Other ai Models
- Maximum Output: 117dB
- Low Cost
- Requires PRO DSP Processor/Loudspeaker Controller



DESCRIPTION

The LFC-12v was designed as a lower-cost alternative to the highly successful LFC-212ai making possible multiple-subwoofer designs in budget-conscious systems. The LFC-12v has the same width and height as the LFC-212ai, but is even one-inch shallower at only 6" deep, making it the ideal choice in rooms where space is limited.

The LFC-12v is also the perfect LFE solution for media room systems based around the ALC-3316 9-channel loudspeaker controller. The ALC-3316's 300W channels have adequate power to achieve reference-level output from the high-sensitivity LFC-12v, at a low cost and with minimal system complexity. Never before has achieving the famous PRO sound been simpler or more affordable.

SPECS

APPLICATION:	Architectural format subwoofer
LF SECTION:	12" professional grade woofer with 4" voice coil
CROSSOVER:	8th order acoustic via DSP
POWER HANDLING:	700W
SENSITIVITY:	96dB
POWER REQUIREMENTS:	Requires amplification via PRO power loudspeaker controller
POWER RECOMMENDATION:	300W, 450W or 1000W
FREQUENCY RANGE:	22Hz - 80Hz
MAXIMUM OUTPUT:	117dB
NOMINAL IMPEDANCE:	4-ohms
DIMENSIONS:	60"H x 14"W x 6"D
WEIGHT:	76 lbs.

LFC-212ai Subwoofer

KEY FEATURES

- Architectural Installation™ Cabinet Design: 7-inch Total Depth for Easy Built-In Installation
- Dual Professional 12-inch, 1000W Drivers with 4-inch Voice Coils
- High Sensitivity: 101dB
- Enclosure Depth Matched to SCRS-8ai and SCRS-12ai
- Configurable Impedance: 2 x 8 ohms, 4-ohms, or 16-ohms
- Maximum Output: 119dB
- DSP Optimized Performance
- Requires PRO DSP Processor/Loudspeaker Controller



DESCRIPTION

Big bass without the big box! Every movie enthusiast understands the significance of low frequency energy in reproducing Hollywood's dramatic sound effects. However, the physical space required for placement of large subwoofer enclosures can often be hard to find. This quest becomes even more difficult when attempting to utilize multiple subwoofers to achieve uniform bass distribution. The LFC-212ai offers an elegant solution.

Measuring only 14" wide and 7" deep, the LFC-212ai has been designed for "in-wall" installation. Though shallow in form, each LFC-212ai contains two 12" professional-grade sub-bass drivers powered by the identical motor system employed in the LFC-18sm. At nearly 30 lbs. each, the massive magnets and 4" voice coil design maximize thermal power handling, assuring tight, articulate bass complete with the visceral slam experienced at the commercial theater.

Designed as part of a sophisticated digital cinema system, the LFC-212ai and companion DPA loudspeaker controller employ advanced Digital Signal Processing (DSP) to precisely match its acoustic transfer-function to that of the larger LFC-18sm and LFC-15sm. As such, all PRO subwoofers may be used interchangeably, or in-concert within the same system. In addition, the LFC-212's dual drivers may be configured in series or parallel, resulting in either a lower impedance load to maximize the output power of the loudspeaker controller, or a higher impedance load, allowing multiple units to be driven from a single high-powered loudspeaker controller channel for dramatic results in large room applications.

SPECS

APPLICATION:	Architectural format subwoofer
LF SECTION:	Dual 12" professional grade woofers with 4" voice coil
CROSSOVER:	8th order acoustic via DSP
POWER HANDLING:	1000W (AES) / 2000W continuous
SENSITIVITY:	101dB
POWER REQUIREMENTS:	Requires amplification via PRO power amplifier
POWER RECOMMENDATION:	450W or 1000W
FREQUENCY RANGE:	22Hz - 80Hz
MAXIMUM OUTPUT:	119dB
NOMINAL IMPEDANCE:	Configurable: 2 x 4-ohms / 8-ohms
DIMENSIONS:	60"H x 14"W x 7"D
WEIGHT:	105 lbs.

LFC-14sm Subwoofer

KEY FEATURES

- Professional 15-inch, 1000W Driver with 3-inch Voice Coil
- Ultra-Compact Enclosure — only 16" x 16" x 12" (without grille)
- Companion Subwoofer for the SCRS-25ica/SCRS-5iw
- Maximum Output: >115dB
- 4-ohm Nominal Impedance
- DSP Optimized Performance
- Requires PRO DSP Processor/Loudspeaker Controller



DESCRIPTION

The LFC-14sm was developed to provide subwoofer (LFE) support in surround systems based upon the SCRS-25ica and SCRS-5iw high-output architectural loudspeakers. A proprietary, extremely long-throw 15" professional-grade woofer is used in a compact sealed enclosure and tuned via DSP to match the acoustic response of PRO's larger vented subwoofers. The result is the same visceral yet tight bass quality that users have come to expect from Pro Audio Technology, but in a compact, easy-to-integrate form factor.

The ultra compact enclosure is small enough to fit inconspicuously within any living decor and the 12" depth (without grille) makes locating the subwoofer inside cabinets or millwork a breeze. The included fabric grille provides a finished look for installations where the woofer will be seen and the input terminals are located on the cabinet bottom, concealed from view.

SPECS

APPLICATION:	Compact format subwoofer
LF SECTION:	15" professional grade woofer with 3" voice coil
CROSSOVER:	8th order acoustic via DSP
POWER HANDLING:	1000W
SENSITIVITY:	90dB
POWER REQUIREMENTS:	Requires amplification via PRO power loudspeaker controller
POWER RECOMMENDATION:	300W, 450W or 1000W
FREQUENCY RANGE:	22Hz - 80Hz
MAXIMUM OUTPUT:	>115dB
NOMINAL IMPEDANCE:	4-ohms
DIMENSIONS:	16"H x 16"W x 13.5"D (12" D without grille)
WEIGHT:	49 lbs.

LFC-15sm Subwoofer

KEY FEATURES

- Professional 15-inch, 1000W Driver with 4-inch Voice Coil
- High-Sensitivity: 96dB
- Enclosure Depth Matched to SCR-12sm
- Maximum Output: >120dB
- 4-ohm Nominal Impedance
- DSP Optimized Performance
- Requires PRO DSP Processor/Loudspeaker Controller



DESCRIPTION

Designed as a mate to the SCR-12sm loudspeaker, the LFC-15sm provides the visceral slam and weight of the cinematic experience in an installation friendly form measuring only 12" deep. Similar in many respects to the LFC-18sm, it employs a single 15" driver powered by the same massive motor system found in its larger sibling. Weighing nearly 30 lbs., the large magnet provides enormous force to the driver, assuring that bass response is tight and articulate. In addition, the 4" voice coil maximizes thermal power handling, resulting in concussive dynamics while allowing the LFC-15sm to perform at sustained high output levels without the distortion or dynamic compression so common in traditional consumer audio designs.

Developed as part of a sophisticated digital cinema system, the LFC-15sm and its companion PRO loudspeaker controller employ advanced Digital Signal Processing (DSP) for high resolution frequency response shaping optimized for cinema soundtrack reproduction. In addition, the LFC-15sm is sonically optimized to blend seamlessly with all PRO loudspeaker systems, creating a single, powerful full-range voice. Maximum output is >120dB. A minimum of two units is recommended for system balance and improved low frequency distribution.

SPECS

APPLICATION:	Medium format subwoofer
LF SECTION:	15" professional grade woofer with 4" voice coil
CROSSOVER:	8th order acoustic via DSP
POWER HANDLING:	1000W (AES) / 2000W continuous
SENSITIVITY:	96dB
POWER REQUIREMENTS:	Requires amplification via PRO power loudspeaker controller
POWER RECOMMENDATION:	1000W
FREQUENCY RANGE:	22Hz - 80Hz
MAXIMUM OUTPUT:	>120dB
NOMINAL IMPEDANCE:	4-ohms
DIMENSIONS:	38"H x 17"W x 12"D
WEIGHT:	85 lbs.

LFC-18sm Subwoofer

KEY FEATURES

- Professional 18-inch, 1000W Driver with 4-inch Voice Coil
- High-Sensitivity: 97dB
- Enclosure Depth Matched to SCR-15sm
- Maximum Output: >120dB
- 4-ohm Nominal Impedance
- DSP Optimized Performance
- Requires PRO DSP Processor/Loudspeaker Controller



DESCRIPTION

The LFC-18sm is a large format subwoofer designed to meet the demands of Hollywood's most challenging movie soundtracks. Its 18" driver provides 254 sq. inches of radiating surface supported by dual 4" ports, allowing the LFC-18sm to move large volumes of air on demand. At the core of the system stands a massive motor system weighing nearly 30 pounds. Its 4" voice coil maximizes thermal power handling, assuring that bass stays tight and articulate with concussive dynamics far beyond those experienced with traditional consumer subwoofer designs. And at a highly efficient 97dB, the LFC-18sm is capable of performing at sustained high output levels without the distortion and dynamic compression commonly associated with lesser designs.

Developed as part of a sophisticated digital cinema system, the LFC-18sm and its companion PRO loudspeaker controller employ advanced Digital Signal Processing (DSP) for high resolution frequency response shaping optimized for cinema soundtrack reproduction. In addition, the LFC-18sm is sonically optimized to blend seamlessly with all PRO loudspeaker systems, creating a single, powerful full-range voice.

Maximum output is >120dB. A minimum of two units is recommended for system balance and improved low frequency distribution.

SPECS

APPLICATION:	Large format subwoofer
LF SECTION:	18" professional grade woofer with 4" voice coil
CROSSOVER:	8th order acoustic via DSP
POWER HANDLING:	1000W (AES) / 2000W continuous
SENSITIVITY:	97dB
POWER REQUIREMENTS:	Requires amplification via PRO power loudspeaker controller
POWER RECOMMENDATION:	1000W
FREQUENCY RANGE:	22Hz - 80Hz
MAXIMUM OUTPUT:	>120dB
NOMINAL IMPEDANCE:	4-ohms
DIMENSIONS:	30"H x 22"W x 16"D
WEIGHT:	114 lbs.

LFC-21sm Subwoofer

KEY FEATURES

- Professional 21-inch, 3000W Driver with 6-inch Voice Coil
- Powerful Neodymium Ring Motor System
- High-Sensitivity: 95dB
- Enclosure Depth Matched to SCR-15sm
- Maximum Output: >124dB
- 4-ohm Nominal Impedance
- DSP Optimized Performance
- Requires PRO DSP Processor/Loudspeaker Controller



DESCRIPTION

The LFC-21sm was conceived as a mate to the SCR-3215sm to provide low frequency support at the same performance level achieved by our reference screen channel loudspeakers. The criteria for its design were simple; present every sound accurately, with the same sense of force and visceral energy that would be experienced in real life... be believable. In this endeavor the LFC-21sm subwoofer system is simply without peer.

When we think "subs" we think "moving air"... and no product moves more air with more force than the LFC-21sm. Its 21" driver is sourced from Europe's leading manufacturer of professional audio components. With nearly 350 sq. inches of radiating surface supported by two 6" ports, the LFC-21sm moves air in abundance; and it does it with speed and articulation of detail seldom associated with large subwoofer designs. Its unique neodymium ring magnet and huge 6" voice coil supply enormous force to the driver, resulting in a highly linear excursion and a uniquely visceral listening experience.

Engineered as a statement product, the LFC-21sm and its companion DPA loudspeaker controller are part of a sophisticated digital cinema system employing Digital Signal Processing (DSP) for high resolution frequency response shaping and crossover filters. In addition, the LFC-21sm is sonically optimized to blend seamlessly with PRO loudspeaker systems, creating a single, coherent full-range voice. Maximum output is >124dB. A minimum of two units is recommended for proper system balance and improved low frequency distribution.

SPECS

APPLICATION:	Large format subwoofer
LF SECTION:	21" professional grade woofer with 6" voice coil. Neodymium motor
CROSSOVER:	8th order acoustic via DSP
POWER HANDLING:	1600W (AES) / 3000W continuous
SENSITIVITY:	95dB
POWER REQUIREMENTS:	Requires amplification via PRO power loudspeaker controller
POWER RECOMMENDATION:	1000W
FREQUENCY RANGE:	19Hz – 80Hz
MAXIMUM OUTPUT:	>124dB
NOMINAL IMPEDANCE:	4-ohms
DIMENSIONS:	48"H x 23"W x 15"D
WEIGHT:	155 lbs.

LFC-24sm Subwoofer

KEY FEATURES

- Professional 24-inch, 2000W Driver with 6-inch Voice Coil
- Driver Alone Weighs 88 pounds
- Ultra-High Sensitivity: 99dB
- Quad Maximum-Flow, Low-Noise 6-inch Ports
- Maximum Output: >129dB
- 4-ohm Nominal Impedance
- DSP Optimized Performance
- Requires PRO DSP Processor/Loudspeaker Controller



DESCRIPTION

The LFC-24sm subwoofer is our ultimate subwoofer offering. Besting even our own LFC-21sm in output, visceral energy and dynamic headroom, the LFC-24sm delivers a seemingly unlimited sense of acoustic power. But the LFC-24sm isn't only an acoustic brute; it delivers the lowest frequencies with articulation and finesse, rendering the subtleties of motion picture and music low frequencies with effortless clarity.

At the heart of the design lies an 88 lb. 24" low frequency transducer of an unequaled design and execution. Capable of dissipating 2000W of power for 2 hours continuous, the LFC-24sm is guaranteed to provide many years of trouble-free performance. Four low-distortion, free-flow 6" ports augment the woofer output at the very lowest audio frequencies and increase overall power handling and efficiency of the system.

The LFC-24sm marries the seemingly disparate qualities of power and finesse to deliver the most effortless, most articulate most powerful low frequencies available.

The LFC-24sm must be heard to be believed.

SPECS

APPLICATION:	Maximum output subwoofer
LF SECTION:	24" professional grade woofer with 6" voice coil. Neodymium motor
CROSSOVER:	8th order acoustic via DSP
POWER HANDLING:	1000W (AES) / 2000W continuous
SENSITIVITY:	99dB
POWER REQUIREMENTS:	Requires amplification via PRO power loudspeaker controller
POWER RECOMMENDATION:	1000W
FREQUENCY RANGE:	22Hz - 80Hz
MAXIMUM OUTPUT:	>129dB
NOMINAL IMPEDANCE:	4-ohms
DIMENSIONS:	26"H x 60.5"W x 21"D
WEIGHT:	266 lbs.

PIVOT BRACKET KIT

KEY FEATURES

- Allows Mounting and **Aiming** of S and SR Series Loudspeakers
- Included with SR-12ai and SR-212ai Models
- Optional with SR-26im/SR-6im/SR-25im and S-12sm Models
- Kit includes 2 brackets and associated hardware
- Speakers under 50lbs require 1 kit per speaker
- Speaker over 50lbs. require 2 kits per speaker



DESCRIPTION

The PRO PIVOT BRACKET KIT was developed to address the need to aim the loudspeakers at the reference listening position within Dolby Atmos surround sound systems. Aiming the speakers at the listening position insures that the timbre or “quality” of the sound does not change as the soundtrack objects move within the surround sound-field by placing the listener “on-axis” of all speakers within the system.

The PIVOT BRACKET KIT is compatible with **SR-26im, SR-6im, SR-25im** (one kit per speakers required) and **S-12sm** (2 kits per speaker required) models as an **option**.

PRO PIVOT BRACKETS are **included** with **SR-12ai and SR-212ai** models.

Aiming the loudspeakers speakers in this way is perhaps the single highest-value improvement that can be realized within a modern surround sound sysetm and is highly recommended.

SPECS

APPLICATION:	Mounting and aiming of PRO S and SR series loudspeakers
DIMENSIONS:	3.5"H x 6.375"W x 3"D
WEIGHT:	0.9 lbs. each

SYSTEM CONTROLLER

KEY FEATURES

- Rack-Mountable, Compact, Fanless Windows 10 PC
- Resides Permanently in Equipment Rack
- Provides Remote Access and Monitoring of PRO Loudspeaker Controllers
- Accommodates up to 18 Loudspeaker Controllers with Optional USB Hub
- Pre Configured by PRO for Each System
- Wifi and Ethernet Connectivity



DESCRIPTION

The PRO SYSTEM CONTROLLER is a compact, fanless PC that resides in the equipment rack and facilitates remote programming and monitoring of up to 18 PRO Loudspeakers Controllers.

Pre-programmed at the factory for each system, the SYSTEM CONTROLLER allows PRO engineers and service technicians to program, update and enhance the PRO Loudspeaker Controller firmware over the life of the system, remotely via a secure IP connection.

SPECS

APPLICATION:	Remote programming and monitoring of PRO loudspeaker controllers
DIMENSIONS:	1.5"H x 7.7"W x 4.8"D
WEIGHT:	4.5 lbs. each