

D

C

B

A

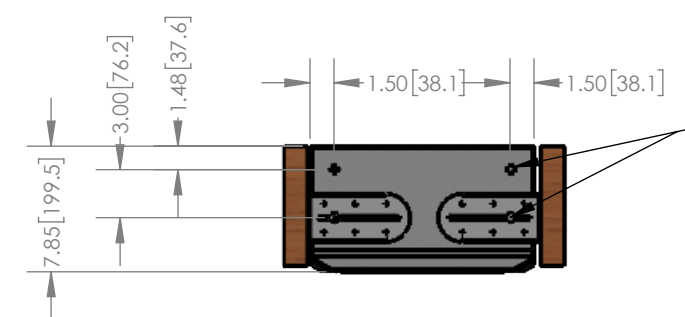

TOP VIEW (INSTALLED)

EITHER MOUNT POINT MAY BE USED

PRO PIVOT BRACKET INCLUDED (4 EACH) MAY BE MOUNTED TO ANY MOUNT POINT ON SIDES, TOP AND BOTTOM (SEE PAGE 2)

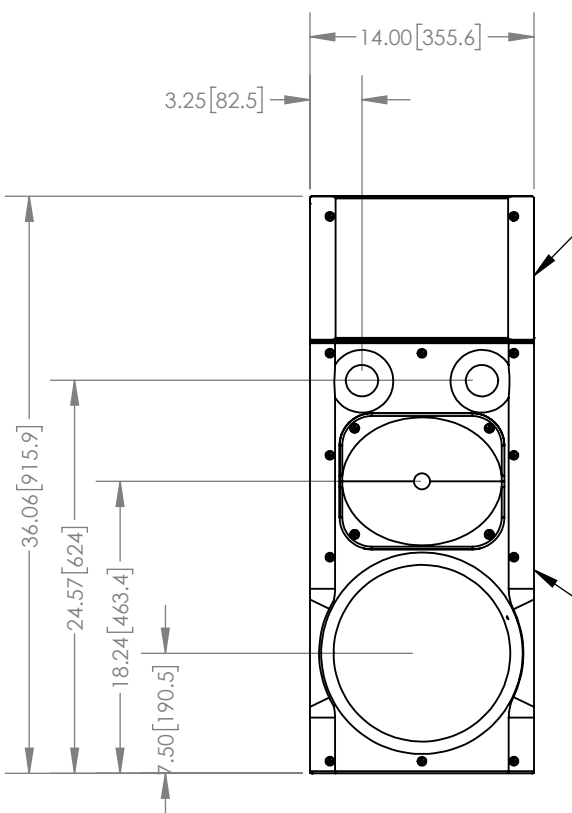

FRONT VIEW

SPEAKER CAN BE INSTALLED WITH HORN UP (AS SHOWN) OR HORN AT THE BOTTOM
USE HORN UP ORIENTATION WHEN PAIRING WITH SR-12ai-LF AUXILIARY WOOFER MODULE TO MAKE MODEL SR-212ai FULL RANGE LOUDSPEAKER

SPEAKER BAFFLE REMOVABLE FOR STORAGE DURING CONSTRUCTION

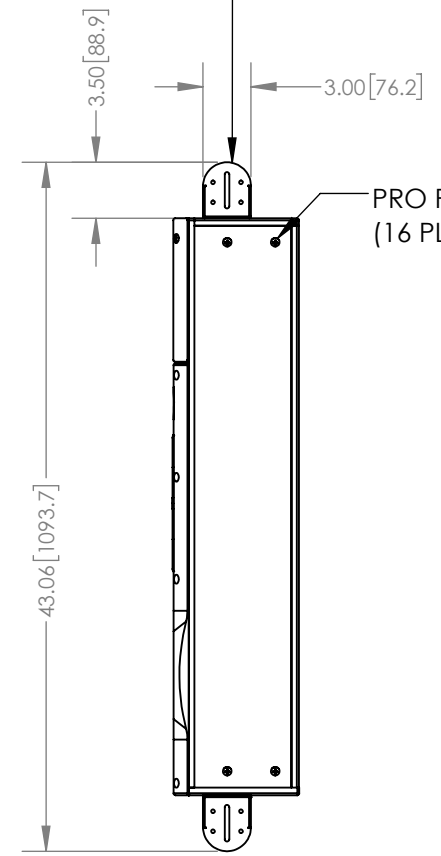

SIDE VIEW

PRO PIVOT BRACKET MOUNT POINTS (16 PLACES). USE INSTALLED SCREWS.

SPEAKER BAFFLE REMOVABLE FOR STORAGE DURING CONSTRUCTION

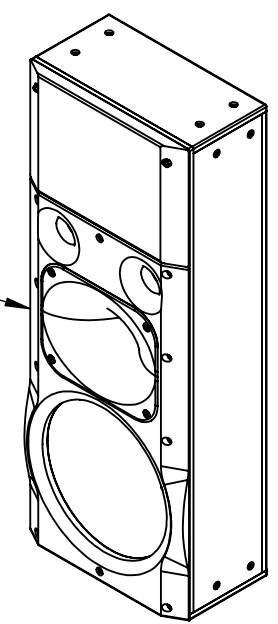

ISO VIEW

NOTES

1. BAFFLE WITH DRIVERS ATTACHED MAY BE REMOVED AND STORED DURING CONSTRUCTION.
2. 4 X PRO PIVOT BRACKETS INCLUDED AND MAY BE MOUNTED TO ANY 1/4"-20 MOUNT POINT ON SIDES, TOP AND BOTTOM AND ALLOWS EASY LOUDSPEAKER AIMING.
3. ALL FOUR SUPPLIED BRACKETS MUST BE USED TO SUPPORT THE WEIGHT OF THE LOUDSPEAKER.
4. **MODEL SR-12ai REQUIRES BI-AMP OPERATION. 4 CONDUCTORS REQUIRED.**
5. SPEAKER CAN BE PAIRED WITH SR-12ai-LF AUXILIARY WOOFER MODULE TO CREATE MODEL SR-212ai.

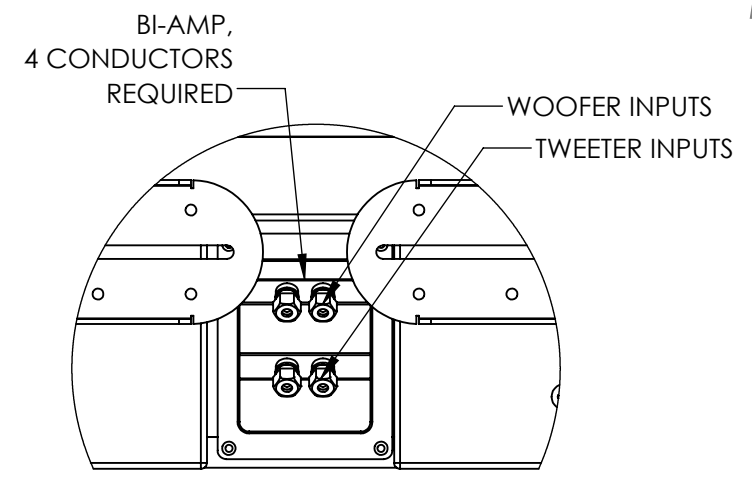

**DETAIL A : INPUT TERMINALS
SCALE 1 : 4**

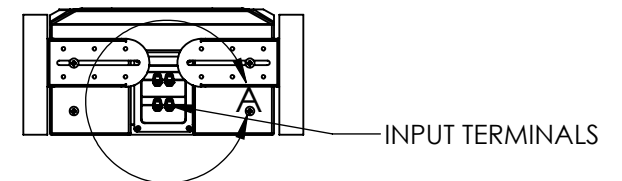

BOTTOM VIEW

PROPRIETARY AND CONFIDENTIAL
THE INFORMATION CONTAINED IN THIS DRAWING IS THE SOLE PROPERTY OF PROFESSIONAL HOME CINEMA, LLC. ANY REPRODUCTION IN PART OR AS A WHOLE WITHOUT THE WRITTEN PERMISSION OF PROFESSIONAL HOME CINEMA, LLC IS PROHIBITED. THE HOLDER OF THIS DOCUMENT SHALL KEEP ALL INFORMATION CONTAINED HEREIN CONFIDENTIAL AND SHALL PROTECT THE SAME IN WHOLE OR IN PART FROM DISCLOSURE AND DISSEMINATION TO ALL THIRD PARTIES.

		UNLESS OTHERWISE SPECIFIED:		NAME	DATE	PROFESSIONAL HOME CINEMA, LLC TITLE: SR-12ai DIMENSIONS AND WIRING SIZE B PART NO. REV SCALE: 1:12 WEIGHT: SHEET 1 OF 2
		DIMENSIONS ARE IN INCHES		DRAWN		
		TOLERANCES:		CHECKED		
		FRACTIONAL ±		ENG APPR.		
		ANGULAR: MACH ± BEND ±		MFG APPR.		
		TWO PLACE DECIMAL ±0.01		Q.A.		
		THREE PLACE DECIMAL ±0.01				
		INTERPRET GEOMETRIC TOLERANCING PER:				
		MATERIAL				
		FINISH				
NEXT ASSY	USED ON	APPLICATION		DO NOT SCALE DRAWING		

D
C
B
A

D
C
B
A

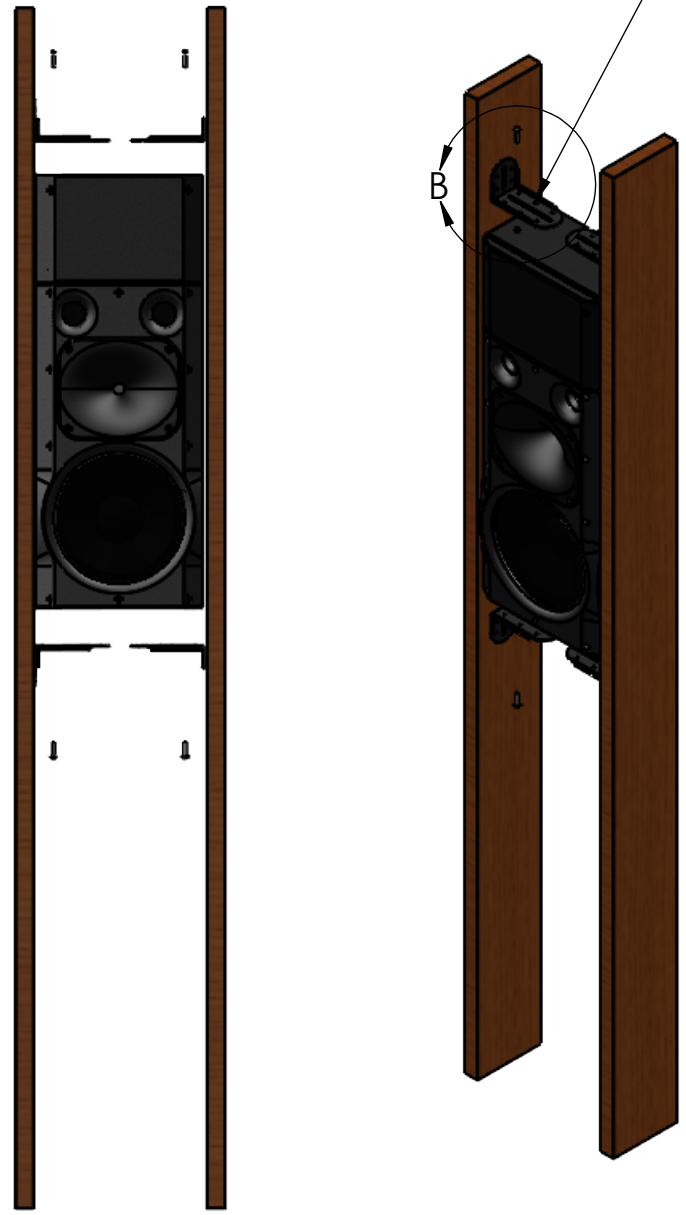

STUD MOUNT - STRAIGHT

USE ALL FOUR BRACKETS - TWO ON TOP, TWO SUPPORTING BOTTOM OF LOUDSPEAKER

ATTACH BRACKETS TO SPEAKER WITH 1/4"-20 SCREWS INSTALLED IN SPEAKER MOUNT POINTS.

ATTACH BRACKETS TO STUDS USING SUPPLIED LAG SCREWS.

B

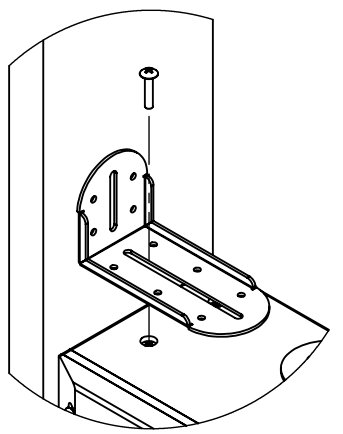

**DETAIL B
SCALE 1 : 6**

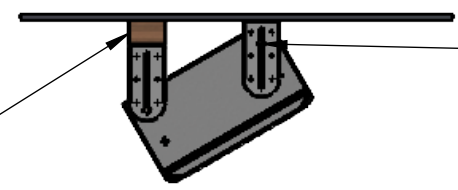

A SHIM (NOT INCLUDED) MAY BE USED TO ACHIEVE GREATER ANGLES

USE 1/4"-20 SCREWS INSTALLED IN ENCLOSURE TO MOUNT PIVOT BRACKETS

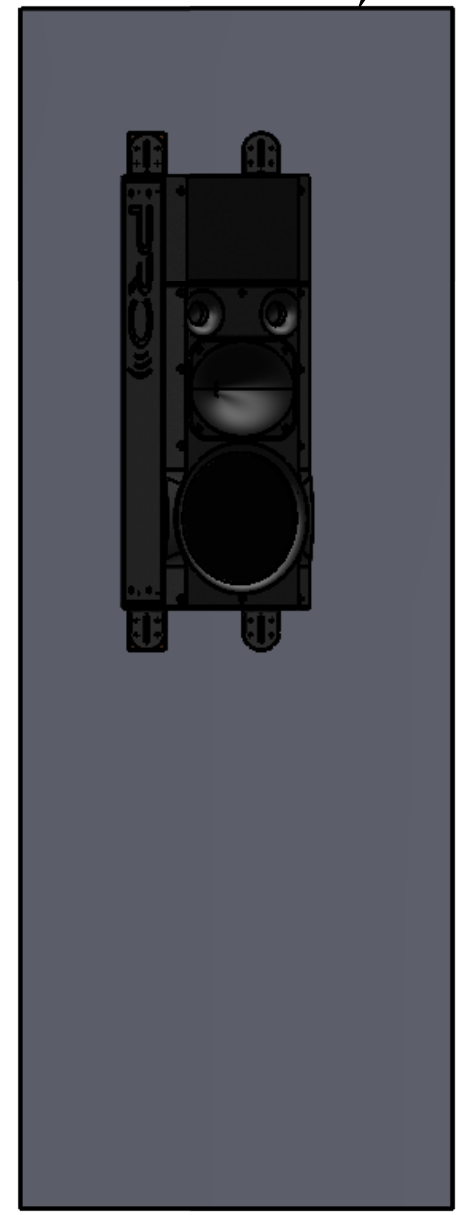

SURFACE MOUNT - AIMED

MOUNTING SURFACE (BY OTHERS)

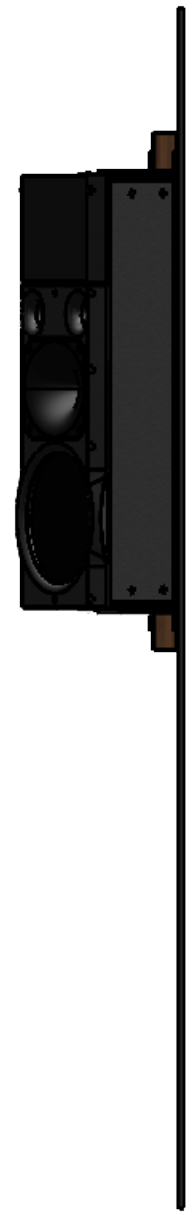

TITLE: SR-12ai INSTALL GUIDE	SIZE B	PART NO.	REV
PROFESSIONAL HOME CINEMA, LLC	SCALE: 1:16	WEIGHT:	SHEET 2 OF 2